

TEAC® A-1250S

STEREO TAPE DECK
SERVICE MANUAL

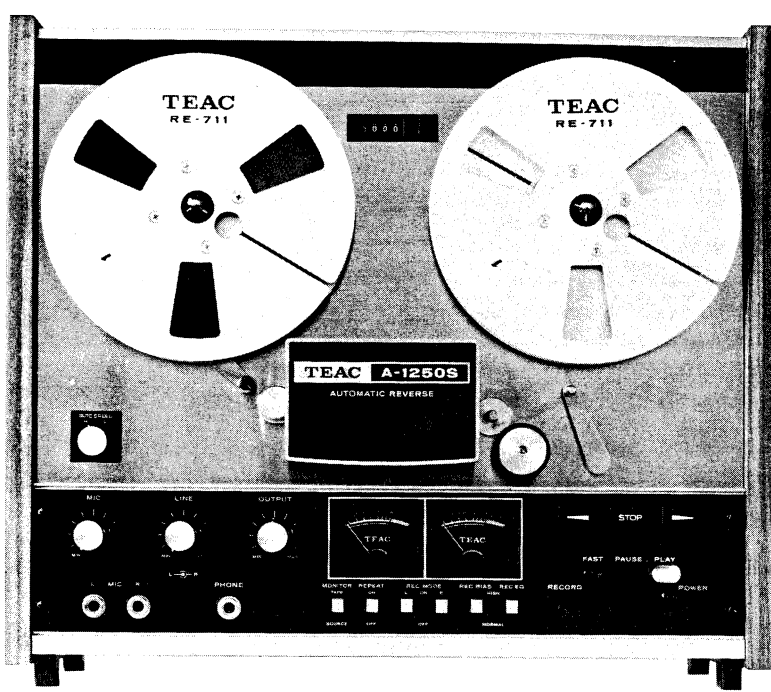

TEAC CORPORATION

SALES OFFICE: SHINJUKU BUILDING
1-8-1, NISHI-SHINJUKU, SHINJUKU, TOKYO
TEAC HONGKONG LIMITED ROOM NO. 1105
MAIN OFFICE: MELBOURNE PLAZA, 33 QUEEN'S ROAD C.
HONG KONG

U.S. DISTRIBUTOR: TEAC CORPORATION OF AMERICA
7733 TELEGRAPH ROAD
MONTEBELLO, CALIFORNIA 90640
U.S.A.
EUROPEAN DISTRIBUTOR: TEAC EUROPE B.V.
KABELWEG 45-47, AMSTERDAM-W. 2,
HOLLAND

MT1251E100

PRINTED IN JAPAN 0872 · S 007

1 GENERAL DESCRIPTION

The TEAC A-1250S is a semi-professional tape deck for stereophonic and monophonic recording and playback with automatic reverse. It offers operating speeds of 7-1/2ips and 3-3/4ips.

The basic design of the A-1250(A-2500) is highly similar to that of the A-1250S, therefore information in this service manual may be applied to the A-1250(A-2500).

This service manual provides adjustment and alignment procedures, schematic diagrams and parts replacement information and the proper procedures for obtaining necessary repair parts.

If adjustments or repair procedures are not clear or seem difficult to accomplish or should you desire more detailed technical information, please contact your nearest TEAC dealer, TEAC Corporation or affiliated corporations, address's of which are printed in this manual.

INDEX

1. GENERAL DESCRIPTION
 2. SERVICE DATA
 3. EQUIPMENT REQUIRED
 4. PARTIAL DISASSEMBLY
 5. HEAD ALIGNMENT -MECHANICAL-
 6. MEASUREMENT AND ADJUSTMENT -MECHANICAL-
 7. SIMPLIFIED DIAGRAMS (WITH VOLTAGE READINGS)
 8. MEASUREMENT AND ADJUSTMENT -ELECTRICAL-
 9. PREVENTIVE MAINTENANCE
 10. TROUBLE SHOOTING
 11. PACKING FOR SHIPMENT AND WARRANTY
- SCHEMATIC DIAGRAMS
PRINTED CIRCUIT BOARD AND PARTS LIST
EXPLODED VIEW AND PARTS LIST
MANUAL CHANGES

2 SERVICE DATA

MECHANICAL

TYPE: Four track 2 channel stereophonic
Four track 1 channel monophonic

HEADS:
(permalloy) Erase/Rec combination x 1
Play Back x 2

REEL SIZE: 7" maximum NAB reel

TAPE WIDTH: Standard 1/4 inch tape

TAPE SPEED: 7-1/2ips and 3-3/4ips ($\pm 0.5\%$)

MOTORS: Two 6-pole eddy current motors for
reel drive.
4/8 pole hysteresis synchronous
capstan motor.

WOW AND FLUTTER: 0.12% at 7-1/2ips
0.15% at 3-3/4ips
Wow and flutter measured according
to weighted NAB standard using
TEAC flutter free tape.

FAST WINDING TIME: Approx. 90 seconds or less for
1,200 feet.

OPERATING POSITION: Horizontal and vertical

POWER REQUIREMENTS: 100/117/200/220/240 V AC 50/60Hz 140W

WEIGHT: 37.5 lbs (17.3 kg)net.

ELECTRICAL

TRANSISTORS: 2SC372(Y) x 12 2SC733(Y) x 2
2SC369(BL) x 6 2SC971 x 2
2SA494(Y) x 2

FREQUENCY RESPONSE: Over all from recording INPUT
to playback OUTPUT
7-1/2ips 40Hz - 18kHz ± 3 dB
3-3/4ips 50Hz - 10kHz ± 3 dB

INPUT: MIC: 0.3mV/10k Ω
LINE: 0.1V/100k Ω

OUTPUT: LINE: approx. 0.3V/10k Ω or more
HEADPHONE: 0.3mW/8 Ω

SIGNAL-TO-NOISE RATIO: 7-1/2ips 48dB or higher
3-3/4ips 46dB or higher at playback

BIAS FREQUENCY: 100 \pm 5kHz push-pull oscillator

CROSSTALK REJECTION: 35dB or more, adjacent track at 100Hz

CHANNEL SEPARATION: 45dB or more, Channel to channel
at 1kHz

ERASE EFFICIENCY: 60dB or more at 7-1/2ips

NOTE

As a result of continuing changes and improvements during the production run, minor differences may be found between early and later machines. Refer to manual change sheets for information concerning modifications.

3 EQUIPMENT REQUIRED

FOR MECHANICAL MEASUREMENT

SPRING SCALE: 0 - 4kg (0 - 8 lbs) #5086025000
0 - 300g(0 - 10 oz) #5086026000

TEST TAPE: TEAC YTT-2003 (7-1/2ips)
TEAC YTT-2002 (3-3/4ips)

FLUTTER METER: Meguro Model MK665B (preferred) or
Sentinel FL-3D-1

DIGITAL FREQ. COUNTER: Capable of 0 to 5kHz indication

TOOLS: General,
2 mm nut driver #5086014000,
Hex head, allen wrench #5086021000

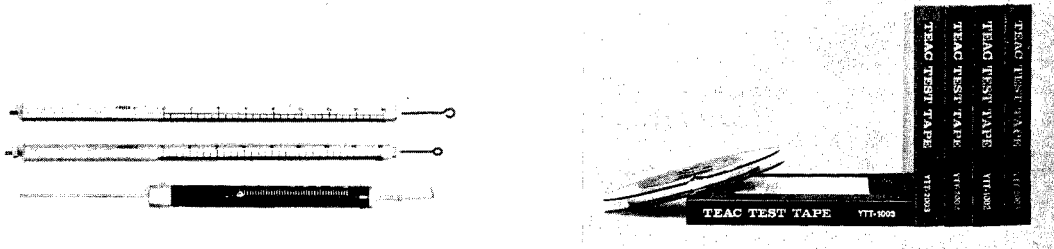

Fig. 3-1 Spring Scale and TEAC Test Tape

FOR ELECTRICAL MEASUREMENT

TEST TAPE: TEAC YTT-1003 for 7-1/2ips
TEAC YTT-1002 for 3-3/4ips
SCOTCH 203 and 150 for test recording

EMPTY REEL: TEAC RE-702 (2" hub)
TEAC RE-701 (4" hub)

TEST SET: TEAC M-826A test set

BAND PASS FILTER: TEAC M-260A (1kHz)

VTVM: hp model 4302B or equivalent

RESISTOR: Non inductive type 8 ohm/1W

OSCILLOSCOPE: General purpose

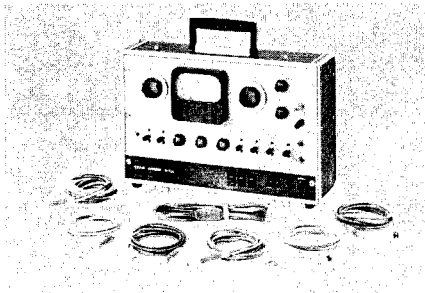
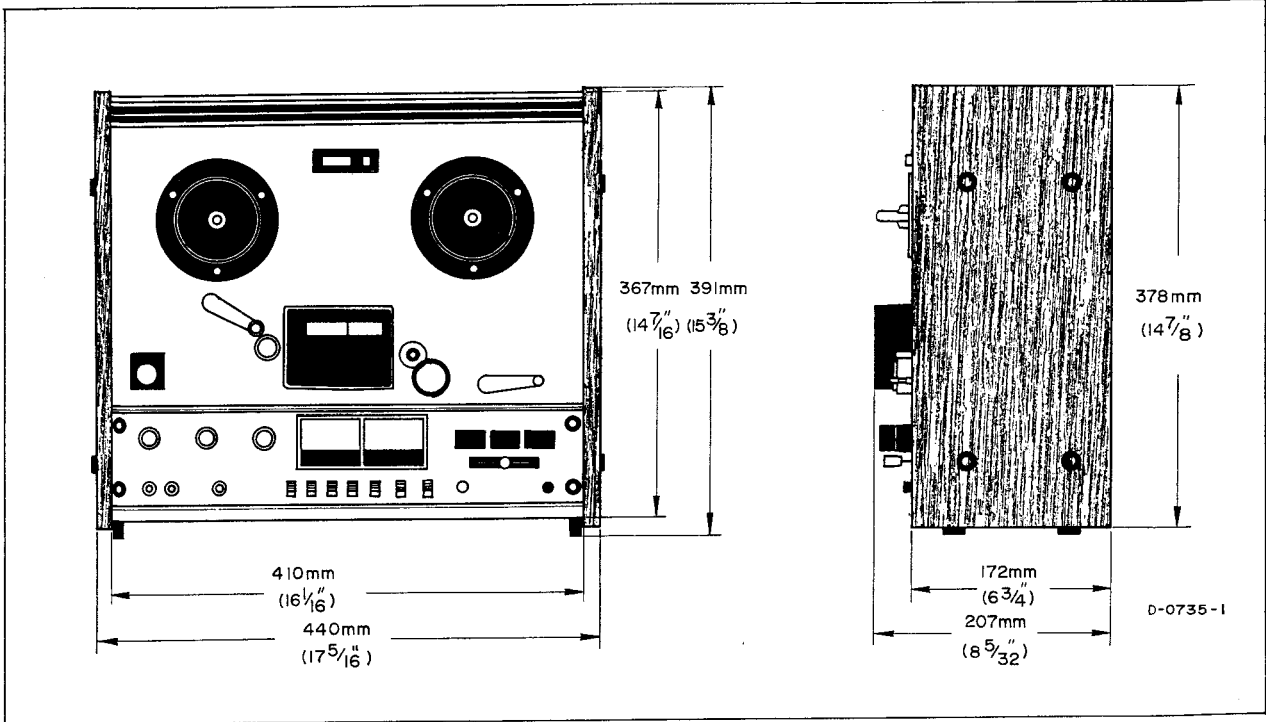

Fig. 3-2 TEAC M-826A

NOTE: Use of the TEAC M-826A test set is recommended. This set incorporates an AC VTVM, Audio Oscillator, Channel Selecting switch, Variable Attenuator, Monitor Speaker and Cables.

TEAC M-826A measures the RMS value of the Voltage (0dB = 0.775V). Characteristics of this test set are similar to the standard VU-meter.

DIMENSIONS A-1250 S



4 PARTIAL DISASSEMBLY

REMOVING WOODEN SIDES AND REAR PANEL

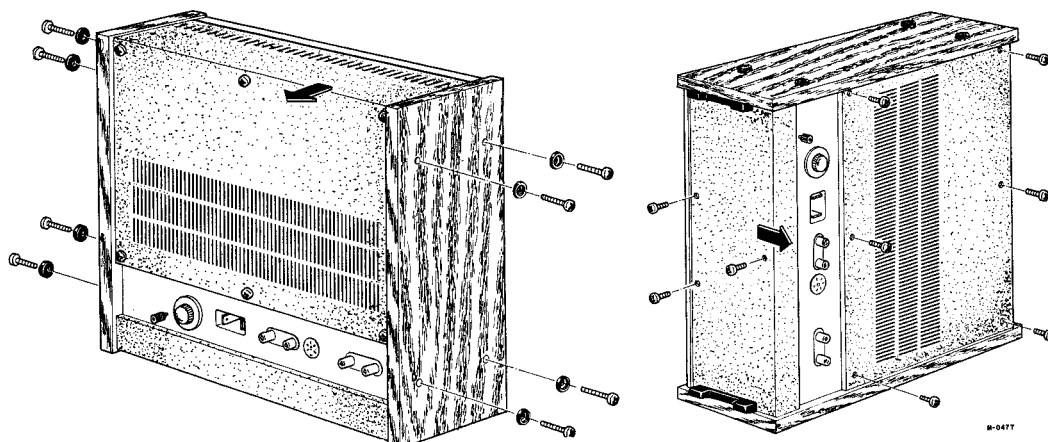

- Wood Sides -

- Rear Panel and Bottom Plate -

NOTE: All amplifier checks and adjustments can be made from the bottom with the plate removed. These adjustments should be performed by experienced technicians, and then only when going through the complete test and check procedures on the unit which is being tested.

HEAD ASSEMBLY REMOVAL

To change the head assembly as a unit, remove the two mounting screws, (one on each end). Note the positions of the wires on the circuit board before unsoldering. Solder the wires of the new assembly in exactly the same position.

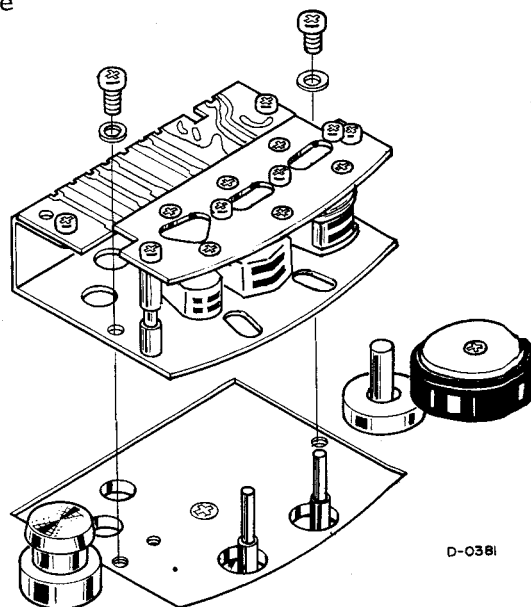

Fig. 4-1 Head Assembly Removal

REMOVAL OF CAPSTAN MOTOR

1. Remove the three screws holding the capstan motor.
2. Unsolder the six wires connecting the capstan motor.
3. Remove the four screws holding the capstan motor.
4. Loosen the two set screws (hex head) in pulley and lift off pulley.

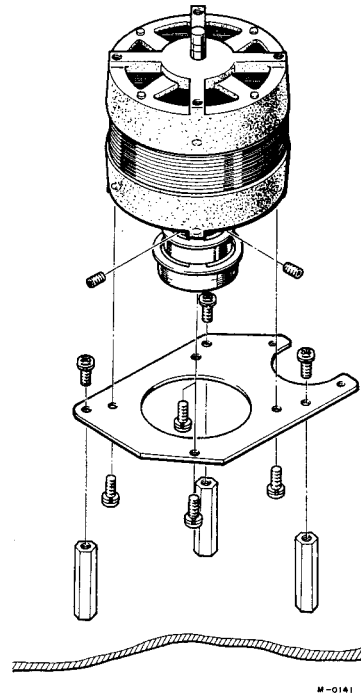

Fig. 4-3 Capstan Motor Removal

REMOVAL OF CAPSTAN ASSEMBLY

1. Unscrew capstan cover (front panel).
2. Remove two screws from rear bracket, allow bracket to drop toward floor of case.
3. Remove capstan belt.
4. Loosen two screws in capstan assy flywheel. Remove flywheel.
5. Remove three screws in capstan assy.
6. Gently move capstan assy up and down until it slides out of panel.

NOTE

A clearance of 0.01" must be maintained between the flywheel and the capstan assembly.

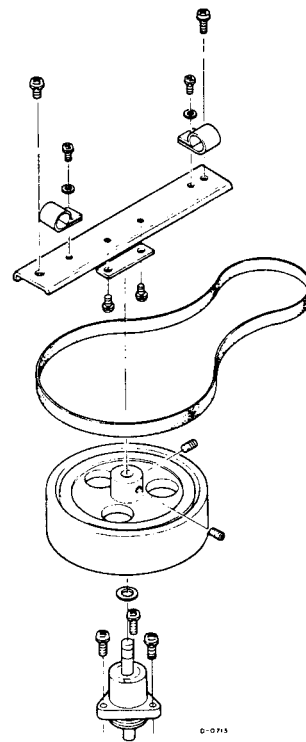
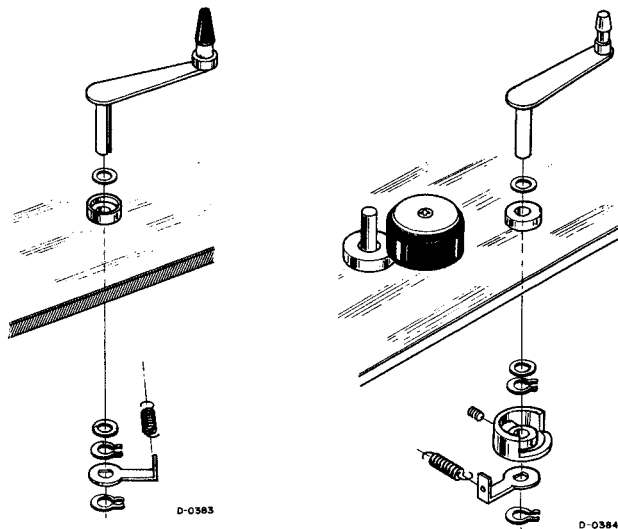

Fig. 4-4 Capstan Assembly Removal

REMOVAL OF TENSION ARMS LEFT & RIGHT

See illustration for complete disassembly instructions.

IMPORTANT
After reassembly check clearance to ascertain that arm moves freely and is not binding.



REMOVAL OF REEL MOTOR ASSEMBLY

1. Loosen 2 hex screws in brake drum, lift off brake drum.
2. Remove 3 screws securing the brake assembly to the motor.
3. Remove reel turntable, remove 4 screws securing motor to front panel.

NOTE

Reel motor assemblies are mirror images of each other, these assemblies are not interchangeable.

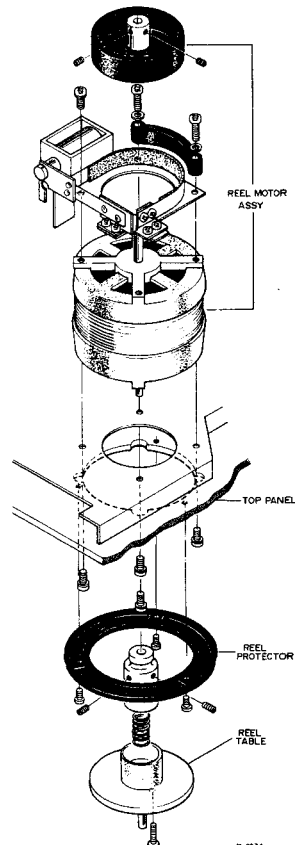
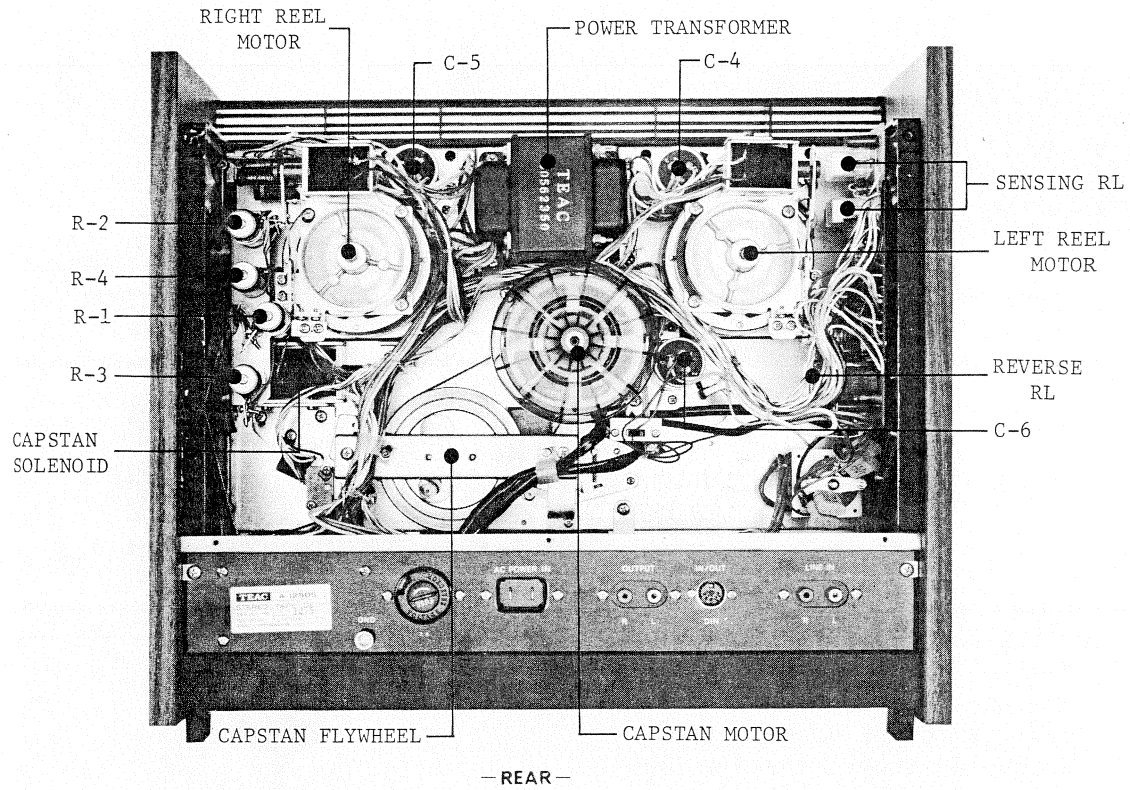

Fig. 4-5 Reel Motor Removal

TAPE TRANSPORT PARTS LOCATIONS



NOTE: For ordering parts, refer to the exploded view of the PARTS LIST. An accompanying listing provides the correct part numbers.

5 HEAD REPLACEMENT AND ALIGNMENT -MECHANICAL-

HEAD REPLACEMENT

NOTE: Head alignment is adjusted at the factory to very critical tolerance. Normally HEAD ASSEMBLY replacement will require only minor alignments or adjustments. Complete readjustment will be necessary after a head is replaced. The adjustments are explained on the next page.

Procedures

To replace a single head, a special 2 mm nut driver is required. Remove the two nuts on the defective head through the access hole provided, this releases the head from the mounting plate. Note the position of the wires on the circuit board. Connect the new head in the same manner. Replace the nuts securing the new head to the plate, perform head alignment before operation.

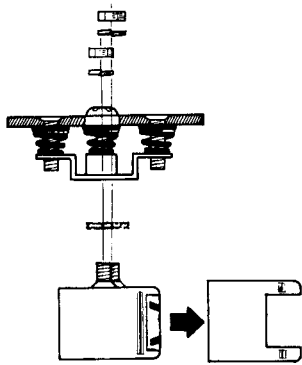

Fig. 5-1 Head Replacement

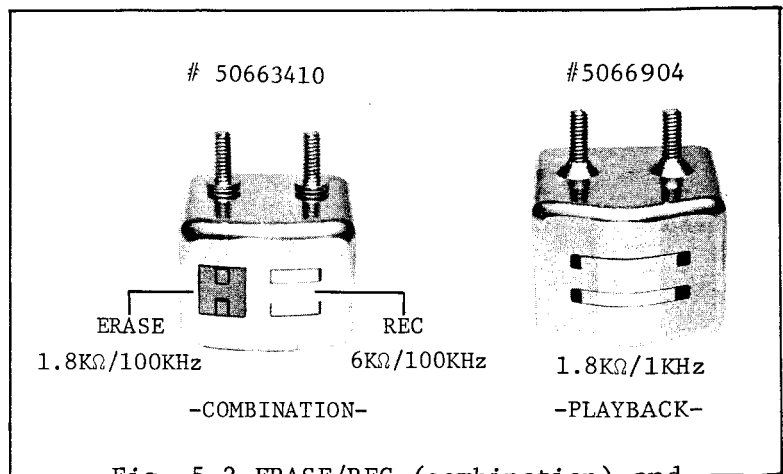
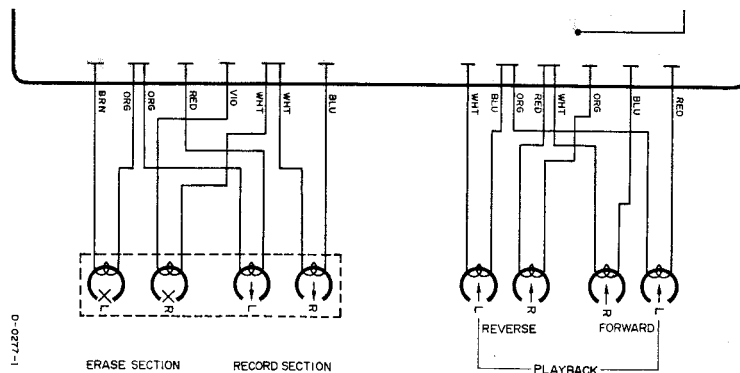

Fig. 5-2 ERASE/REC (combination) and PB Head Configuration



NOTE: Combination Head
The position of the wires on the circuit board. Connect the new head in the same manner.

Fig. 5-3 Head wiring

HEAD ALIGNMENT

■ ERASE/RECORD COMBINATION HEAD

The record head pole should be above the edge of a threaded tape by the width of thin pencil line. Erase section should be a heavy pencil line above.

■ PLAYBACK HEADS

Forward side: The forward playback head pole should be even with the top of a threaded tape.

Reverse side: The pole of the reverse playback head should be even with the bottom of a threaded tape.

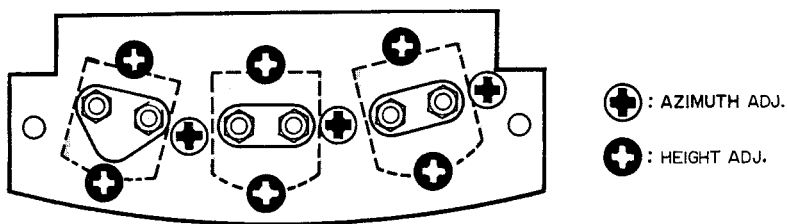

D-0388

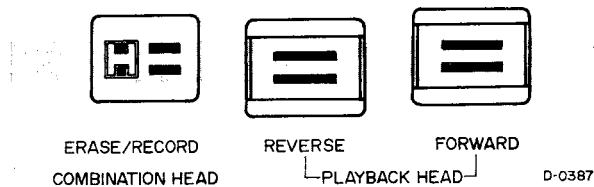

Fig. 5-4 Head Alignment and Adjustment Screws

● **ALIGNMENT** - The physical positioning of a tape head relative to the tape itself. Alignment in all respects must conform to rigid requirements in order for a unit to function properly.

● **AZIMUTH** - The angle of a tape heads pole-piece slot relative to the direction of tape travel.

NOTE: In order for a tape unit to work at its best, with its own tapes as well as ones made on other units, its play and record heads must be aligned to correct the four possible errors as illustrated to the right.

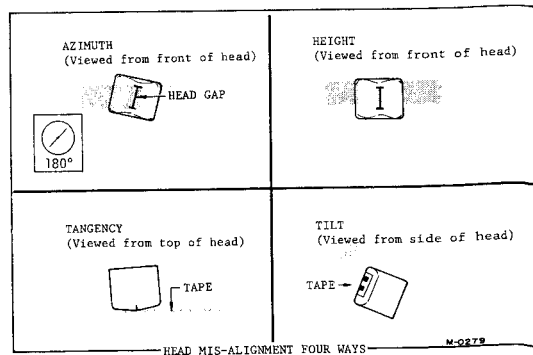

Fig. 5-5 Head Mis-Alignment Four Ways

6 MEASUREMENT AND ADJUSTMENT -MECHANICAL-

The TEAC A-1250S uses a highly reliable three motor drive system and should require a minimum of mechanical maintenance or adjustment. These adjustments are made at the factory. Readjustment should only be required after many hours of operation or component replacement.

PINCH ROLLER PRESSURE

NOTE: Pinch roller pressure is supplied by the pinch roller spring arm and it is most important that the solenoid plunger be fully bottomed before taking pressure measurement.

Procedure for Check and Adjustment

1. Load tape or block the shut-off arm in the "ON" position.
2. Attach a suitable spring scale to the pinch roller shaft.
3. Place the unit in the PLAY mode (▶), and holding the spring scale as illustrated, slowly draw it away from the pinch roller.
4. Do not allow the string to rub against the pinch roller.
5. Note the reading on the spring scale at the instant the pinch roller stops rotating.
6. The scale should indicate 2.1 - 2.3kg. Optimum value is 2.2kg.
7. If adjustment is necessary, loosen the three screws on the capstan solenoid and position the solenoid for optimum pressure.
8. Adjust solenoid-limit position so that the gap between capstan shaft and pinch roller is approximately 7 mm when solenoid is not actuated. Limit is adjusted by loosening the mounting screw (A), mount slot is elongated, slide limit until proper gap is obtained.

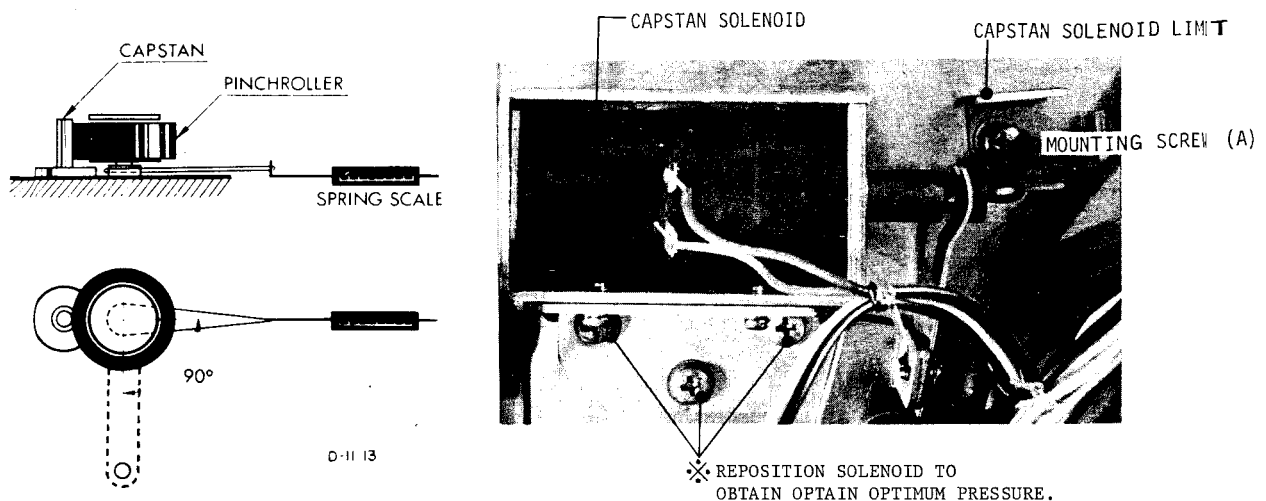

Fig. 6-1 Pressure Measurement and Adjustment Locations

TORQUE ADJUSTMENT PROCEDURE

All Torque and Tension Measurements must be made with the automatic shut-off switch blocked to the "ON" position.

1. Measure the back tension of the left reel motor and the take-up torque of the right reel motor.
 2. Adjust R-1 if measurement value of right or left reel motor exceeds the specified limits. (Coarse adjustment)
 3. After adjusting R-1, adjust R-2 to bring back tension and take-up torque to exact specified limits.
- Refer to next page TORQUE MEASUREMENT PROCEDURE section.

NOTE: Adjustments will interact. Several adjustments may be required to bring both motors within specifications.

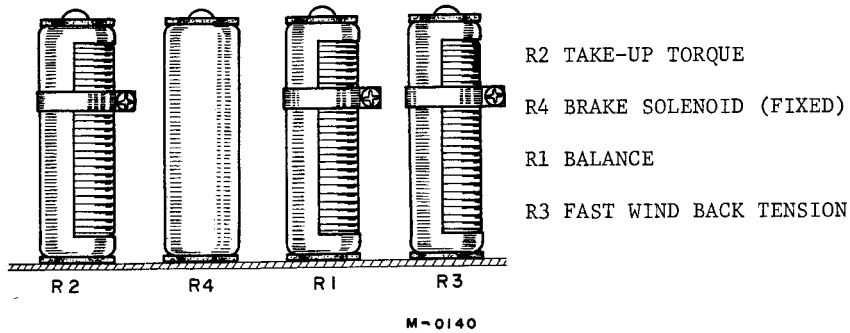

Fig. 6-2 Adjustment Parts Location

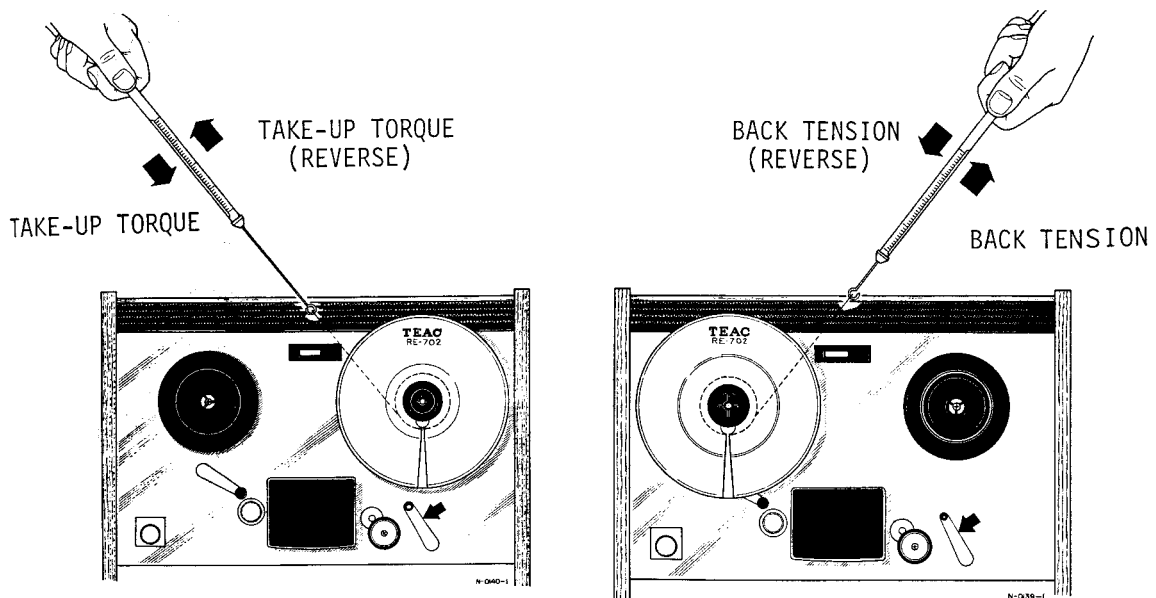

Fig. 6-3 Torque Measurement

TORQUE MEASUREMENT PROCEDURE

BACK TENSION

1. Load tape or block the shut-off arm in the ON position.
2. Place an empty 7" reel with a 2" diameter hub on left reel table.
3. Rotate the reel and wind several turns of string around the hub. Attach spring scale to string.
4. Place the unit in the (▶) play mode.
5. Pull the scale away from the reel against the motor torque, with a steady smooth motion.
6. Note the scale reading while it is in steady motion.
7. Make sure the string does not rub against the reel flanges.
8. The reading should be approximately 180~220g-cm (2.8~3.1 oz-inch).

TAKE-UP TORQUE

1. Place the empty reel and attached spring scale on the right reel table.
2. Place the unit in the (▶) play mode.
3. Allow the rotation of the reel to slowly draw the scale toward the hub.
4. Hold the spring scale with enough force to allow a steady reading.
5. It should be approximately 360~400 g-cm (4.1~4.8 oz-inch).

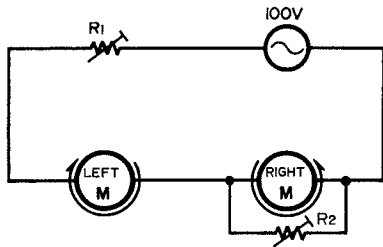

SHOWN IN REVERSE PLAY (◀)

D-0396

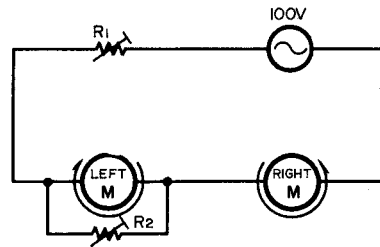

SHOWN IN FORWARD PLAY (▶)

D-0395

REWIND BACK TENSION

1. Load a full 1,800ft reel of tape on the right reel table.
2. Place the empty reel with 2" hub on the left reel table.
3. Place the unit in the fast rewind mode.
4. At this time observe the right tension arm. Adjust R-3 so that the arm moves approx. 1" to the right and remains there.

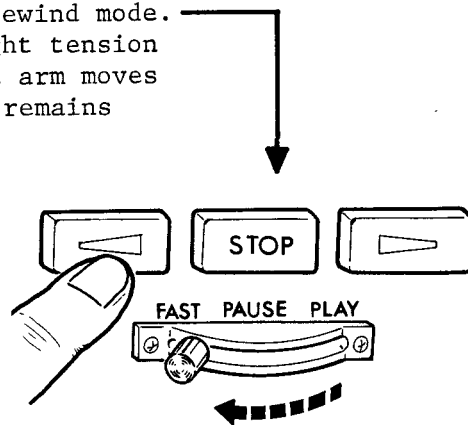
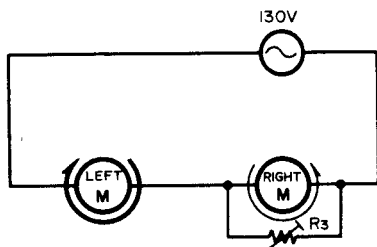

M-0468

BRAKE TORQUE

The brake torque is actuated mechanically. Pressure is set by the variable spring force. While making this measurement and adjustment, be careful not to bend the brake bands. As brake torque will change with cleaning, brake drums and brake shoes should be cleaned only when absolutely necessary. If cleaning is required, use TEAC cleaner TZ-251B only. After cleaning operate the machine for a month of normal operation before performing the below procedures.

Brake adjustments are made with "NO" power connected to the equipment.

Procedure for Check and Adjustment

1. Place an empty 2" hub reel on the left reel table, and fasten one end of a 30" length of string to the reel anchor.
2. Wind several turns of string counterclockwise around the hub and attach a suitable spring scale to the free end of the string.
3. Take a reading only when the reel is in steady motion since the force required to overcome static friction will produce a false, excessively high initial reading.
4. The reading should be 1.8 kg-cm \pm 0.1 (25 oz-inch).
5. If adjustment is required, loosen the two screws shown and position the brake for optimum torque.
6. The adjustment of the right brake is the same, with the exception that rotations are clockwise.

NOTE: The difference in readings between the right and left brakes should be kept within 50 g-cm (0.7 oz-inch).

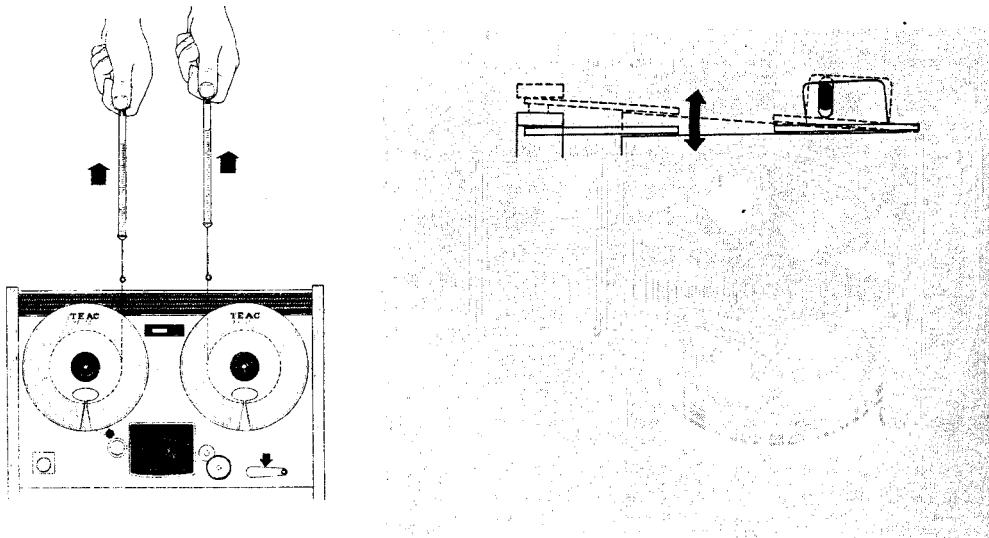

Fig. 6-4 Torque Measurement and Adjustment Location

REEL HEIGHT ADJUSTMENT

Reel height adjustment is required only if a motor has been replaced. Adjustment is accomplished by the FINE ADJUSTMENT screw in the reel turntable. Reel turntable should be adjusted using standard 7" reels. With a tape threaded on the machine, position the reel-height for smooth tape travel.

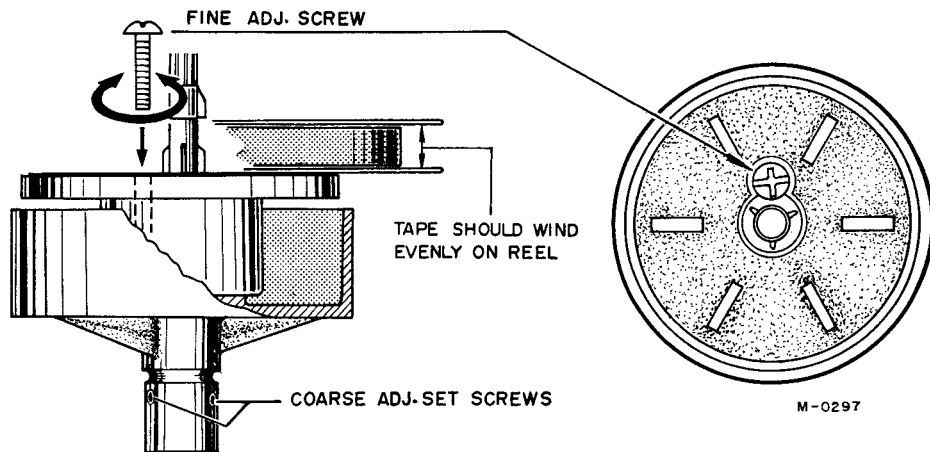

Fig. 6-5 Reel Height Adjustment

FLUTTER

Flutter should be measured in playback mode using a TEAC flutter free tape YTT-2003·2002 and Meguro model MK665B flutter meter. Measurement of flutter should be made in accordance with NAB standards.

Values obtained with different standards or equipment cannot be compared.

Flutter should not exceed. 7-1/2ips: 0.12%
3-3/4ips: 0.15%

These figures apply to any tape position and direction (such as full take-up reel, full supply reel or about mid point).

TAPE SPEED

The tape speed should be measured using TEAC flutter free tape, model YTT-2003·2002. These tapes contain a highly accurate 3 kHz tone. Connect a digital frequency counter to either line OUTPUT jack. The indicated frequency should be 3 kHz $\pm 0.7\%$ for all speeds.

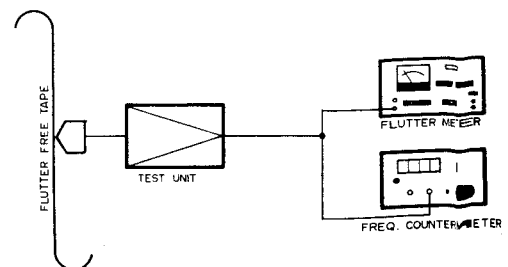

Fig. 6-6 Test Equipment Set-Up

VOLTAGE AND FREQUENCY CONVERSION

Unit must be set to the power line frequency available. Improper frequency setting will result in a 20% error between the tape speed and reel motors torque. [US model is preset to 117V AC and 60 Hz. No frequency conversion is required.]

NOTE: If it should be necessary to convert the A-1250S deck to operate from a power source of different voltage or frequency, it may be easily accomplished as follows:

Voltage Conversion:

The A-1250S may be set for 100, 117, 200, 220 or 240 volts. To change the voltage unscrew the fuse in the center of the voltage selector plug. Pull out the plug and reinsert it so the desired voltage shows in the cut-out. Reinstall the fuse.

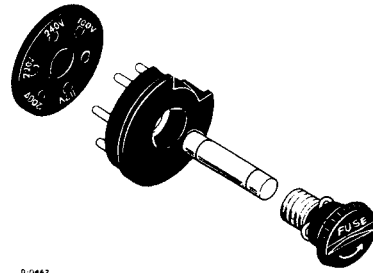

Fig. 6-7 Voltage Conversion

Frequency Conversion:

1. Remove the power cord and all connecting cables.
2. Take off tape deck rear cover by removing the six screws holding it.
3. To convert the unit from 50 to 60 Hz operation reposition the capstan belt as shown in the illustration below.
4. Frequency selector slide switch inside the rear of the tape deck must be switched to the frequency of the power line.
5. Reinstall rear cover.

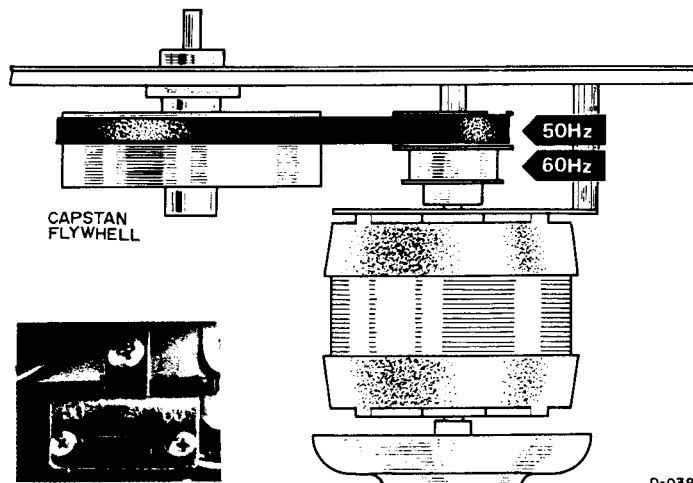
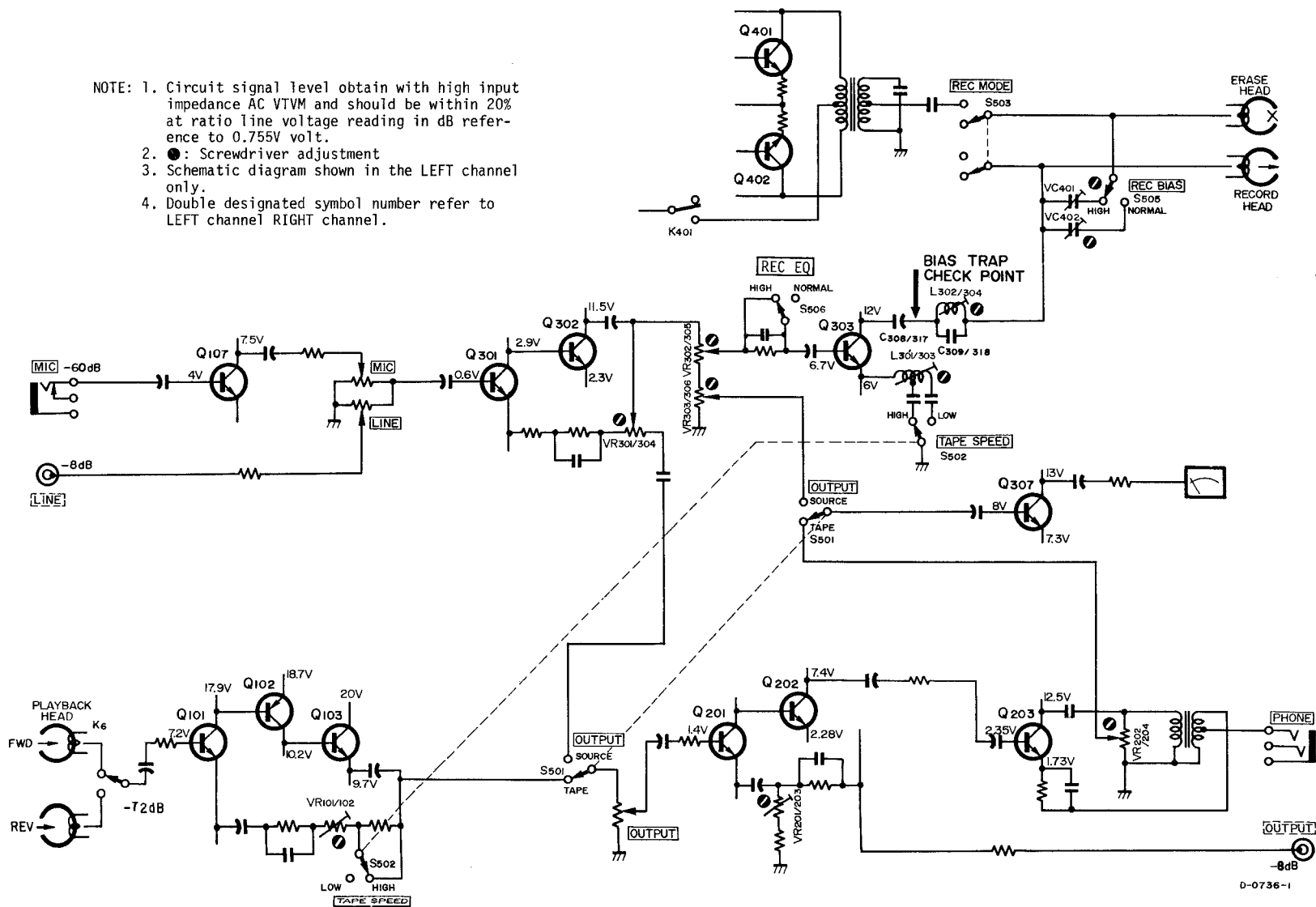

Fig. 6-8 Frequency Conversion

7 SIMPLIFIED DIAGRAM (WITH VOLTAGE READINGS)

A-1250 S

- NOTE: 1. Circuit signal level obtain with high input impedance AC VTVM and should be within 20% at ratio line voltage reading in dB reference to 0.755V volt.
2. ●: Screwdriver adjustment
3. Schematic diagram shown in the LEFT channel only.
4. Double designated symbol number refer to LEFT channel RIGHT channel.



7-1

8 MEASUREMENT AND ADJUSTMENT -ELECTRICAL-

GENERAL NOTICE

Before performing maintenance on this unit, thoroughly clean and demagnetize the entire tape path.

It is important that the unit be set to the proper voltage and frequency for your locality.

TEAC specified standard test tapes and test equipment must be used when performing maintenance to insure reliable results.

Procedures for checks and adjustments, unless otherwise indicated, are for the left channel at a tape speed of 7-1/2ips. The same procedures are to be applied to the right channel and again for both channels at 3-3/4ips, and both directions.

All controls mentioned in this book will be printed in bold letters and will be exactly as they appear on the unit.

Power supply check and adjustment:
Check the voltage at VR-1 and adjust to 24V DC if required. (Refer to control board on the TAPE TRANSPORT CIRCUIT DIAGRAM.)

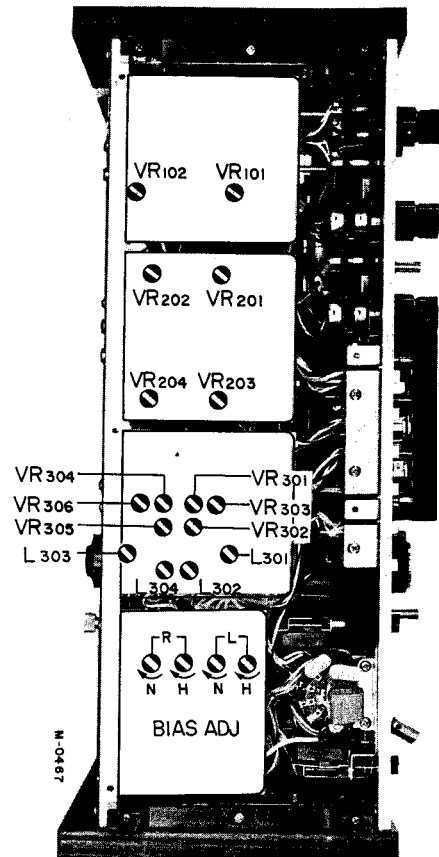

Fig. 8-1 Adjustment Locations

L CHANNEL	R CHANNEL	LOCATION
VR101	VR102	PLAYBACK EQ.
VR201	VR203	PLAYBACK LEVEL
VR202	VR204	PLAYBACK METER LEVEL
VR303	VR306	REC METER LEVEL
VR301	VR304	SOURCE MONITOR LEVEL
L 301	L 303	REC EQ.
VR302	VR305	RECORD LEVEL
L 302	L 304	BIAS TRAP
VC501	VC503	BIAS NORMAL ADJ.
VC502	VC504	BIAS HIGH ADJ.

PLAYBACK PERFORMANCE

PLAYBACK HEAD AZIMUTH ADJUSTMENT

NOTE: After head replacement or if, during playback, a slight pressure on the heads results in a rise of the reading of the level meter, head azimuth adjustments should be accomplished.

Coarse Adjustment

1. Connect a level meter to either OUTPUT jack.
2. Thread a TEAC test tape YTT-1003 on the unit.
3. Play the 15 kHz test tone in section 2 of the test tape.
4. Slowly rotate the azimuth screw until maximum indication is obtained on the level meter.

Fine Adjustment

NOTE: It is absolutely essential to accomplish the coarse adjustment before performing the fine adjustment to avoid phase errors larger than 45°. After coarse adjustment, do not make large corrections, turn azimuth screw 1/4 turn or less.

5. Connect the test equipment as shown in Fig. 8-2 below.
6. Play a 50 Hz~7.5 kHz signal and adjust the azimuth screw until the oscilloscope shows that the signals are less than 45° in phase.
7. Secure the screw with a drop of LOCTITE.

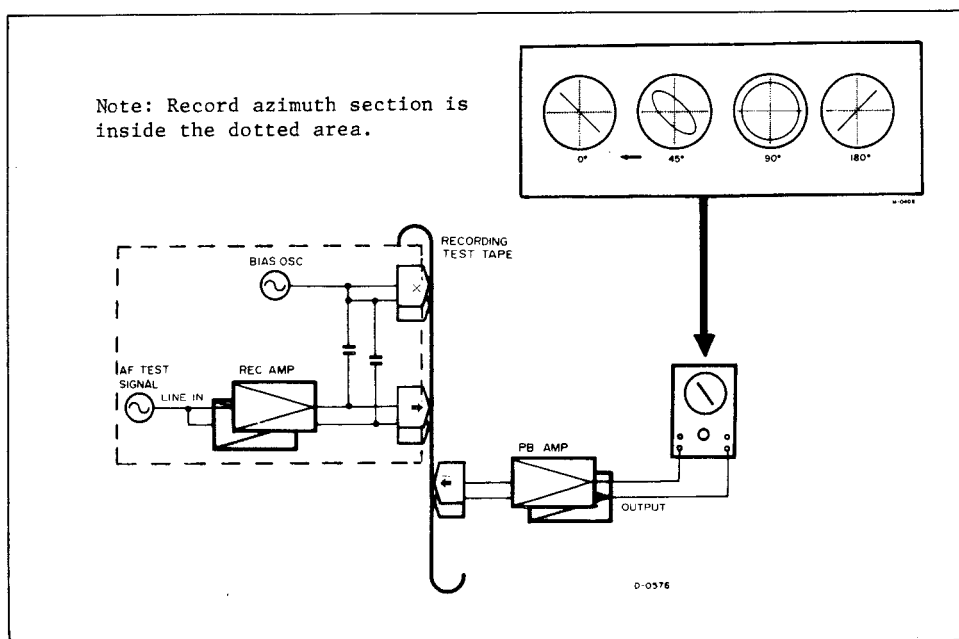

Fig. 8-2 Fine Adjustment Set-Up -Head Azimuth-

SPECIFIED OUTPUT LEVEL SETTING

NOTE: Connect a 10k Ω load to the OUTPUT jacks for all audio measurements when not using TEAC M-826A (0 dB = 0.775V) output meter.

1. Place the MONITOR switch to the TAPE position.
2. Turn the OUTPUT control fully clockwise.
3. Thread TEAC test tape YTT-1003 on the unit. Operate at 7-1/2ips. This tape will apply a 400 Hz signal at operating reference level (1% of the THD level).
4. Adjust VR-201/203 to obtain an output of -2 dB at the OUTPUT jacks.
5. Align the reference marks of controls so that they are at the 2 o'clock position. This will give approximately -8 dB at the OUTPUT jacks.
6. Readjust VR-201/203 for a -8 dB output level at OUTPUT jacks.

IMPORTANT: This is the specified output level setting. Do not disturb this setting until the remaining adjustments have been completed.

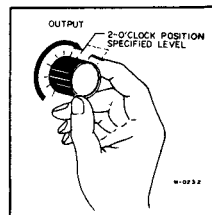

VU METER CALIBRATION

7. While playing the 400 Hz tone (1% THD) in section 1 of the test tape.
8. With MONITOR switch at TAPE position, adjust VR-202/204 for a reading of 0 VU on the VU meter.

FREQUENCY RESPONSE

1. Place TAPE SPEED switch in H (high) position.
2. Thread a TEAC test tape YTT-1003 on the unit.
3. Compare the readings obtained on the level meter with the response limits given in Fig. 8-3.
4. If adjustment is required, adjust VR-101/102 at 7-1/2ips speed.
5. Place TAPE SPEED switch in L (low) position.
6. Thread a TEAC test tape YTT-1002 on the unit.
7. Repeat step 3. Check for best frequency response limits.

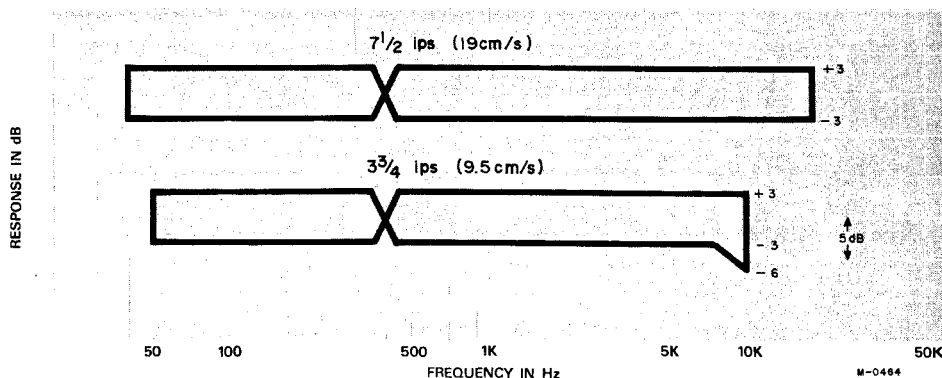

Fig. 8-3 Frequency Response Limits -Playback-

PHONE OUTPUT CHECK

1. Place OUTPUT control at the Specified Level Setting (400 Hz signal at -8 dB).
2. Connect an 8Ω non-inductive resistor across headphone output. Connect level meter across the resistor.
3. Level meter should indicate $-24\text{ dB} \pm 2\text{ dB}$.

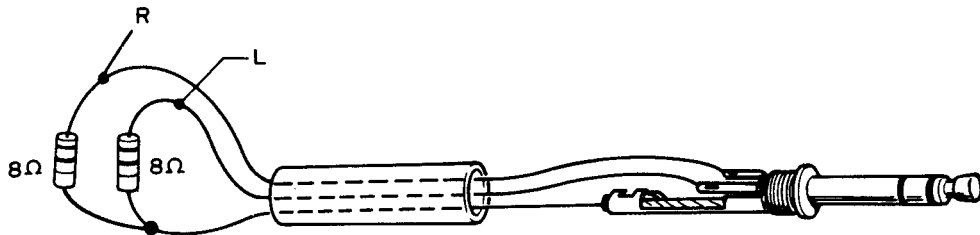

Fig. 8-4 Headphone Connecting Resistor

MONITOR PERFORMANCE

MINIMUM INPUT LEVEL SETTING

LINE Input:

1. Connect an AF oscillator to the LINE IN jacks.
2. Place MONITOR switch in SOURCE, EQ switch, BIAS switch in HIGH position.
3. Apply a 400 Hz signal -18 dB to the LINE IN jacks.
4. Turn LINE control fully clockwise, adjust VR-301/304 to obtain the specified output level of -8 dB at OUTPUT jacks.

MIC Input:

[This is a check only. No adjustments are to be made.]

5. After adjusting VR301/304, apply a 400Hz signal at -60 dB to the MIC IN jacks.
6. Rotate the MIC controls fully clockwise until they give an output of -8 dB (specified output level).

NOTE: Return MIC controls fully counterclockwise (CCW) to prevent noise insertion during the following steps.

VU METER LEVEL SET

Verify OUTPUT controls at the specified output level.

1. Place the MONITOR switch to the SOURCE position.
2. Apply a 400 Hz signal at -8 dB to LINE IN jacks.
3. Adjust VR-303/306 for 0 VU (± 0.5) on the VU meter.

RECORD PERFORMANCE

SPECIFIED INPUT LEVEL SET

1. Apply a 400 Hz signal at -8 dB to the LINE IN jacks.
2. Adjust the LINE control for -8 dB at the OUTPUT jacks.

NOTE: Do not disturb the specified input level position of these controls until the remaining checks and adjustments are completed. The difference between the channels must not exceed ± 2 dB as indicated on the level meter. If they are not within limits, check the amplifier gain and the LINE control settings.

Before making any adjustments on the record amplifier, be sure that all tests in the HEAD ALIGNMENT, PLAYBACK and MONITOR PERFORMANCE sections have been accomplished and that all levels are correct.

Optimum recording performance (bias levels, recording levels and frequency response) is dependent upon tape characteristics. The TEAC A-1250S is factory set with SCOTCH type 203 (HIGH) and SCOTCH type 150 (NORMAL) tape.

BIAS TRAP ADJUSTMENT

NOTE: The bias trap tank circuit keeps the bias signal from reaching the record and monitor amplifier and under normal "no signal" conditions, voltage should not be present at the OUTPUT jacks.

1. Place BIAS switch in HIGH position, MONITOR switch in TAPE position and RECORD MODE switches "ON". Place tape mode lever at the PAUSE position. Depress RECORD and (▶) buttons.
2. Connect a VTVM or oscilloscope to the junction of C-308/L-302.
3. Adjust L-302, L-304 (other channel) for minimum reading.

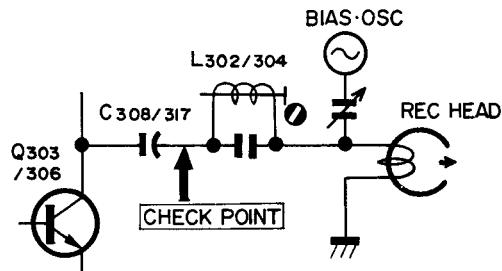

M-0448

Fig. 8-5 Bias Trap Check Point

BIAS ADJUSTMENT

NOTE: Adjust bias traps (above) before proceeding. The following adjustments are only made at 7-1/2ips (19 cm/s) tape speed. The bias oscillator frequency is 100 kHz (± 10 kHz).

HIGH position

1. Thread record test tape SCOTCH 203 on the unit.
2. Place the REC BIAS switch to HIGH and place the unit in the record mode.
3. Place the MONITOR switch in the TAPE position.
4. Apply a 400 Hz signal at -8 dB to the LINE IN jacks.
5. Adjust capacitor VC-401/403 for a peak on the level meter.
6. Turn the capacitors clockwise until a decrease of 0.5 dB is obtained.

NORMAL position

1. Thread record test tape SCOTCH 150 on the unit.
2. Place the REC BIAS switch to NORMAL position.
3. Adjust VC-402/404 as in HIGH position.

RECORD HEAD AZIMUTH ADJUSTMENT

Coarse Adjustment

NOTE: The effect of turning the azimuth screw will not immediately register on the level meter. A slight delay will be noticed. Therefore, the screw must be rotated slightly with a pause to see the effect.

1. Connect a level meter to the OUTPUT jack and an AF oscillator to the LINE IN jack, then set the AF oscillator to 10 kHz.
2. Make certain that the LINE controls are at the specified input level positions.
3. Place the MONITOR switch to SOURCE and adjust the AF oscillator to obtain a signal of 15 dB below the specified output level. (The level meter will indicate -23 dB.)
4. Thread a record test tape on the unit.
5. Place the MONITOR switch in the TAPE position.
6. While recording adjust the azimuth screw for maximum indication on the level meter.

Proceed to the next page "Fine Adjustment".

Fine Adjustment

NOTE: It is absolutely essential to accomplish the coarse adjustment before performing the fine adjustment to avoid phase error larger than 45°.

7. Connect the test equipment as shown in Fig. 8-2.
8. Apply 7.5 kHz signal at -23 dB to the LINE IN jacks and record this signal.
9. Carefully adjust the azimuth screw until the oscilloscope shows the signal to be in phase.
10. Secure the screw with a drop of LOCTITE.

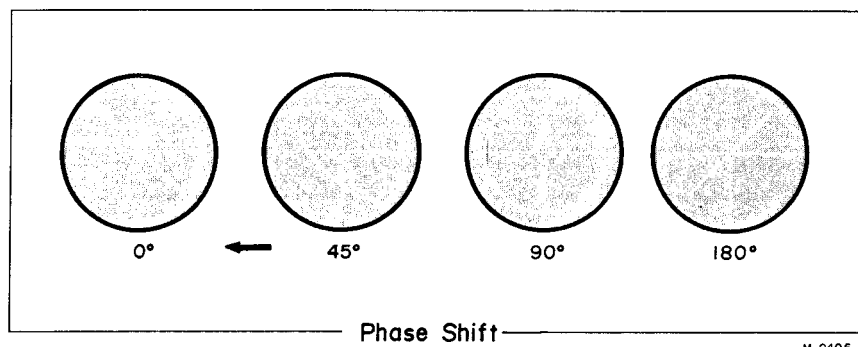

RECORD LEVEL SET _____

NOTE: The OUTPUT control must be at the specified output level position (-8 dB at OUTPUT jacks), and the LINE INPUT controls at the Specified Input Level Setting.

1. Apply a 400 Hz signal at -8 dB to the LINE IN jacks.
2. Thread record test tape SCOTCH 203 on the unit, then set the REC BIAS switch to HIGH position.
3. Place the MONITOR switch in the TAPE position, LINE controls fully clockwise.
4. Adjust VR-302/305 for -8 dB signal at OUTPUT jacks.

OVERALL FREQUENCY RESPONSE

HIGH position

1. Thread a blank SCOTCH 203 tape on the unit, place REC BIAS switch at HIGH, TAPE SPEED at H (high), MONITOR switch at TAPE position.
2. Apply a signal swept from 40 Hz to 18 kHz at -23 dB to LINE IN jacks and record it on the test tape.
3. Adjust L-301/303 for best response.
4. Repeat above procedures for 3-3/4ips using a signal swept from 50 Hz to 7.5 kHz.

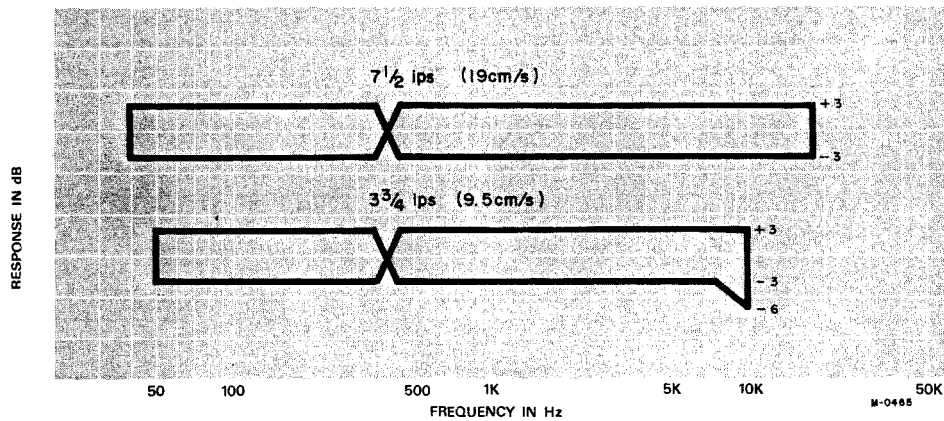

Fig. 8-6 Frequency Response Limits -HIGH-

NORMAL position

5. Thread a blank SCOTCH 150 tape on the unit. Place REC BIAS switch at NORMAL position, TAPE SPEED switch at H (high).
6. Apply a signal swept from 40 Hz to 15 kHz at -23 dB to LINE IN jacks.
7. Repeat overall response check at both speeds.

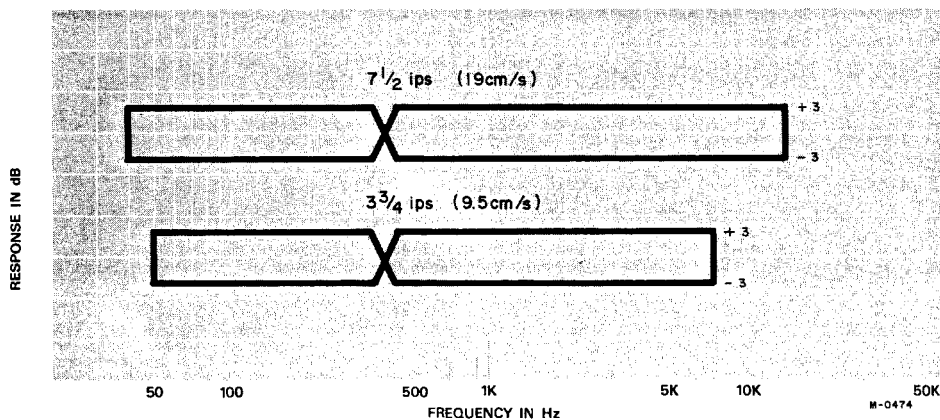

Fig. 8-7 Frequency Response Limits -NORMAL-

SIGNAL-TO-NOISE RATIO

PLAYBACK

IMPORTANT: OUTPUT controls should be at the Specified Output Level settings. The signal-to-noise ratio must meet factory standards. The values given are obtained using an unweighted level meter while the supply and take-up motors have voltage applied but are not rotating. The values are with reference to a 3% THD peak recording level.

1. Thread a blank SCOTCH 203 tape on the unit leaving the tape outside the capstan and pinch roller.
2. Place the unit in the PLAY mode (▶) (the tape will not move using PAUSE).
3. The level meter connected to the OUTPUT jacks should indicate -56 dB or less.
4. This corresponds to a signal-to-noise ratio of 48 dB (difference between residual noise -56 dB and specified output level -8 dB for 1% THD).
For a 3% THD signal-to-noise ratio, 6 dB is added, given 54 dB (3% THD is 6 dB above 1% THD level).

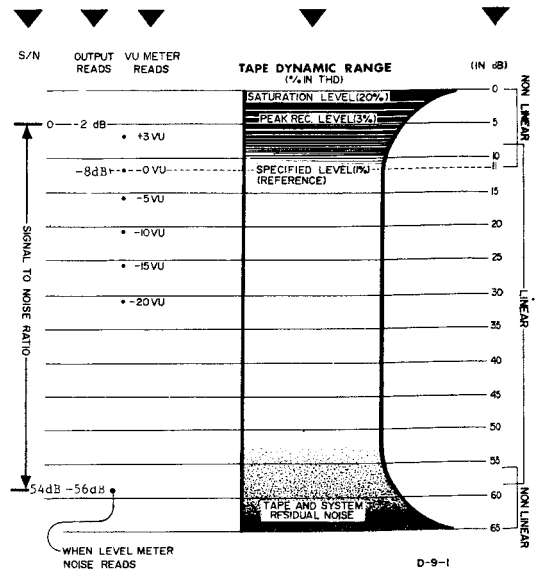

Fig. 8-8 Signal/Noise Computation

OVERALL

IMPORTANT: Clean and demagnetize the heads before proceeding. It is extremely important that all tests described in the preceding paragraphs have been completed and that all controls are left at their specified settings.

1. Thread a blank test tape SCOTCH 203 on the unit.
2. Remove the AF oscillator from the LINE IN jacks.
3. Place the unit in the RECORD mode with "no signal" applied. Note the point on the index counter where recording begins.
4. Rewind the tape to the beginning point and play it back.
5. The noise level as indicated on the level meter should be -54 dB or less.

NOTE: Bias, erase and playback amplifier noise are all included in this measurement. All frequencies between 40 Hz and 15 kHz are measured unweighted.

ERASE EFFICIENCY

NOTE: To measure erase efficiency, a 1 kHz Band Pass Filter (TEAC M-204 CL filter) must be used.

1. Apply a 1 kHz signal at 0 dB to the LINE IN jacks.
2. Place the unit in RECORD mode and record this signal.
3. Rewind the recording to the beginning and remove the AF oscillator from the LINE IN jacks.
4. Place the unit in RECORD mode and record over this portion of tape again.
5. Rewind the tape to the starting point and connect a level meter to the OUTPUT jack through the 1 kHz Band Pass Filter.
6. Play the erased portion of the tape.
7. The level meter should indicate 60 dB or less.

LEVEL VARIATION

1. Thread a blank reel of high output tape SCOTCH 203, and select 7-1/2ips (19 cm/s).
2. Record a variety of frequencies, such as 400 Hz, 2 kHz, 5 kHz, 8 kHz, 10 kHz, etc., at the specified input setting with the REC BIAS switch HIGH position. Record approximately 30 seconds at each frequency.
3. During playback, the output level should not vary more than 0.5 dB at 400 Hz, 1 dB at 5 kHz to 10 kHz.
4. Repeat steps 2 and 3 with the unit at 3-3/4ips (9.5 cm/s). The tolerances are the same.

9 PREVENTIVE MAINTENANCE

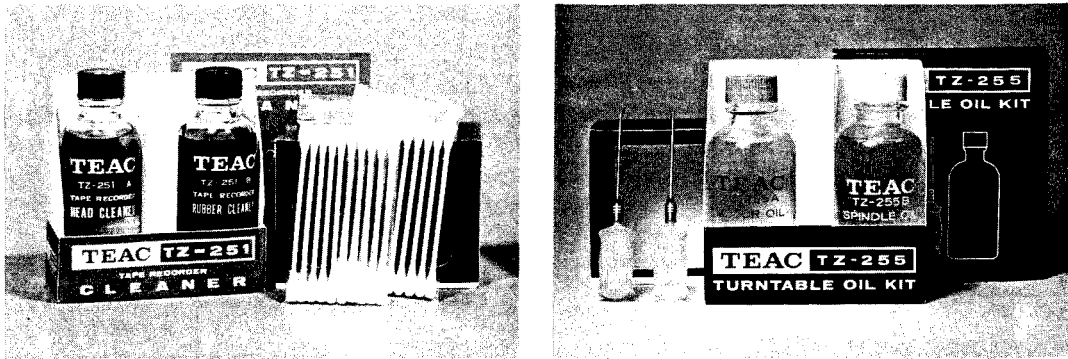

Fig. 9-1 Maintenance Equipment

CLEANING

When excess oxide accumulates on the surface of components where tape passes, normal operation and characteristics cannot be expected. Periodic cleaning should be done with proper cleaning materials. Refer to the Operating Instructions Manual.

DEMAGNETIZATION

Metal parts in contact with the tape will become magnetized after long periods of use (except erase head). Magnetization of record/playback heads causes noise in recording and reproduction and heads should be demagnetized at every 50 hours of use, and before any important recording is done. Refer to the Operating Instructions Manual.

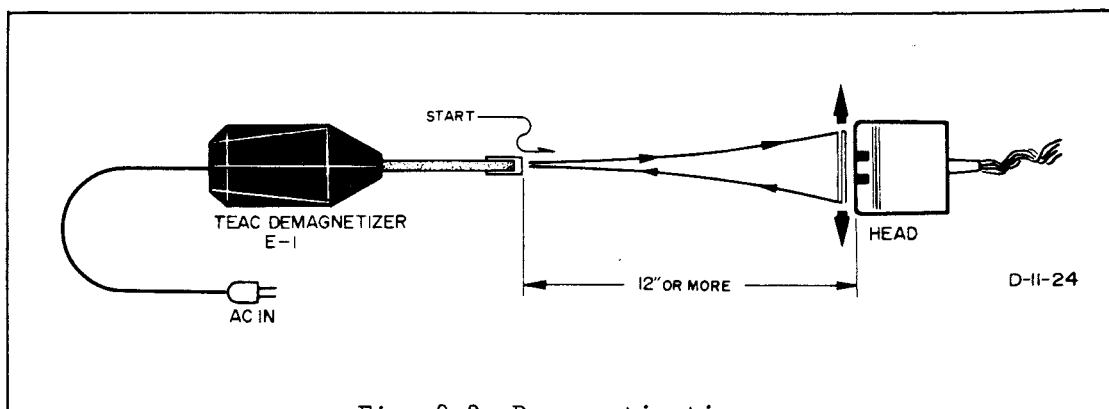

Fig. 9-2 Demagnetization

LUBRICATION

Under normal conditions the unit will not require lubrication. Most of the bearings and bushings are of the oilless type. Since there are many rubber parts in the transport mechanism, excessive or improper lubrication could cause problems. If lubrication is required, the following points should be lubricated:

Capstan bushing, pinch roller shaft 1 drop
Motor 1~2 drops in the plastic tubes

Parts to be lubricated should be cleaned and old oil and dirt removed before relubricating. Observe instructions as to type of oil, points to be lubricated.

Motors should be lubricated immediately after use while still warm. After oiling motors keep the unit in the vertical position for 2~3 hours to allow thorough absorption of oil.

VENTILATION

During use the face plate of the A-1250S may become quite warm to the touch. This is entirely normal.

As long as the air vents in the rear plate are unobstructed, the unit will not overheat.

However, if the unit is placed snugly against a wall, or free air passage is prevented, overheating and possible damage may occur.

10 TROUBLE SHOOTING

NOTE: The following guide lists specific difficulties that could occur in the A-1250S.

Several possible causes are listed for each malfunction. Visually inspect the unit for any damage such as broken or burned components or wiring, loose connections, etc.

MALFUNCTION	POSSIBLE SOURCE OF TROUBLE	CORRECTIVE PROCEDURE
Capstan fails to turn	Belt off or slipping, line fuse, auto-shut off switch (SW-2), phase advance capacitor (C-6), reverse play relay (K-3), speed select switch (SW-8)	Refer to schematic diagram and repair or replace the defective components.
Pinch roller fails to contact capstan in the Reverse mode	Operation relay (K-2), start relay (K-4), reverse relay (K-3), brake switch (SW-10), capstan solenoid, play switch (SW-4)	Refer to schematic diagram and repair or replace the defective components.
Right (Left) reel does not rotate in the play mode	Motor (right or left), brake solenoid, rewind relay (K-1)	Refer to schematic diagram and repair or replace the defective components
Right (Left) reel does not rotate in play mode	Operation relay (K-2), start relay (K-4), brake switch (SW-10)	Refer to schematic diagram and repair or replace the defective components
Does not engage in forward play	Resistor (R-5) or (D-1), play switch (SW-4), operation relay (K-2), brake switch (SW-10), sensing relay (K-5), tension arm pc board (left)	Refer to schematic diagram and repair or replace the defective components
Does not operate in reverse play	Play switch (SW-5), reverse relay (K-3), rewind relay (K-1), start relay (K-4), brake switch (SW-10), diode (D-6), diode (D-9)	Refer to schematic diagram and repair or replace the defective components
Pinch roller 4 second delay faulty	Start relay (K-4), resistor (R-11), capacitor (C-25), diode (D-7)	Repair or replace the defective components
At reverse play, it will stop when pushing the reverse button	Brake switch (SW-10), brake switch (micro SW), loose connection	Defective components, mis-adjustment
Fast forward or rewind mode inoperative	Transformer, rewind relay (K-1)	Refer to schematic diagram and repair or replace the defective components

MALFUNCTION	POSSIBLE SOURCE OF TROUBLE	CORRECTIVE PROCEDURE
No record and/or no erase	Play button (SW-15) Record relay (K-401), diode (D-3), head dirty, bias OSC, record mode switch, record bias switch, record meter ampl.	Refer to schematic diagram and repair or replace the defective components bias adjustment improper (VC-401~VC-404)
No playback	Head dirty, monitor switch, playback amplifier	Refer to playback amplifier voltage chart
Auto-reverse does not function with sensing foil	Foil length too short, sensing post dirty transistor (Q-3, Q-4), resistor (R-20, R-22), sensing relay (K-7) reverse relay (K-3)	Foil should be 1/2" long. Clean sensing post. Repair or replace the defective components
Auto-repeat does not function with sensing foil	Repeat switch (SW-11), sensing post dirty sensing relay (K-7), reverse relay (K-3)	Repair or replace defective components.
Playback noise or hum	Head selector relay (K-6), magnetized head, faulty head, playback amplifier,	Demagnetize and clean head, repair or replace defective components
Noise or hum during recording	magnetized head, faulty connections, MIC level set "MAX", record mode switch, record bias switch, bias OSC, record relay (K-401), record amplifier	Demagnetize and clean head, repair or replace defective components, decrease MIC level control
Wow and flutter	Defective tape, dirty or defective pinch roller, oily or defective belt, reel motor tension, capstan motor, capstan belt	Clean or replace defective components. Adjust motor tension
Incorrect tape speed	50/60Hz cycle-change capstan belt in wrong position. Incorrect pinch roller pressure, frequency selector switch set incorrectly.	Reposition 50/60 Hz belt. Reset cycle-change SW Adjust pinch roller pressure

Should you have any questions concerning this manual, please contact Mr. T. Hishida, Instruction Manual Project Department, your query will receive personal attention.

Address: TEAC Corporation
Sales Office
Instruction Manual Project Dept.
Shinjuku Building
1-8-1, Nishi-Shinjuku,
Shinjuku, Tokyo,
Japan

11 PACKING FOR SHIPMENT AND WARRANTY

SHIPPING INSTRUCTIONS

If the unit is to be sent back to the TEAC factory (service department) for repair, carefully pack as shown below.

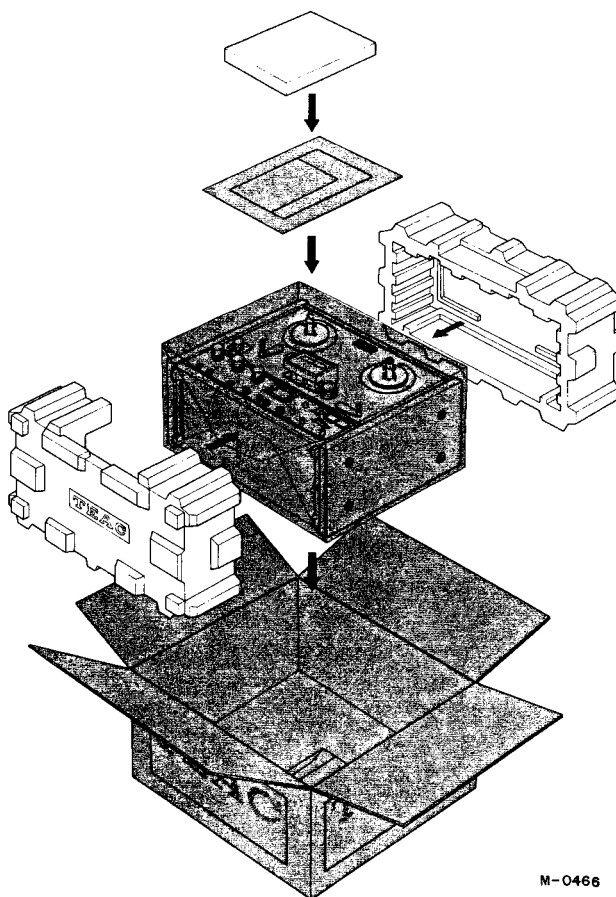

M-0466

Your TEAC equipment has been manufactured under the strictest quality control. Its normal operation is under warranty. However, warranty terms may vary with the country (area) in which it was purchased and for different models of equipment. The warranty terms are fully described on the warranty card. Please read the card for complete details. Include a copy of the warranty in the package when you return the equipment to an Authorized Service Center.

TEAC[®]

A-1250S

**STEREO TAPE DECK
PARTS LIST**

REPLACEMENT INFORMATION

Replacement parts are available through your nearest TEAC dealer or directly from the TEAC office.

Changes are constantly being made to make TEAC products better and more reliable.

Therefore, when ordering parts, always include the following information:

<i>MODEL</i>	<i>SERIAL NO.</i>	<i>REF.NO.</i>	<i>PARTS NO.</i>	<i>DESCRIPTION</i>
--------------	-------------------	----------------	------------------	--------------------

TEAC CORPORATION

TRIM PARTS

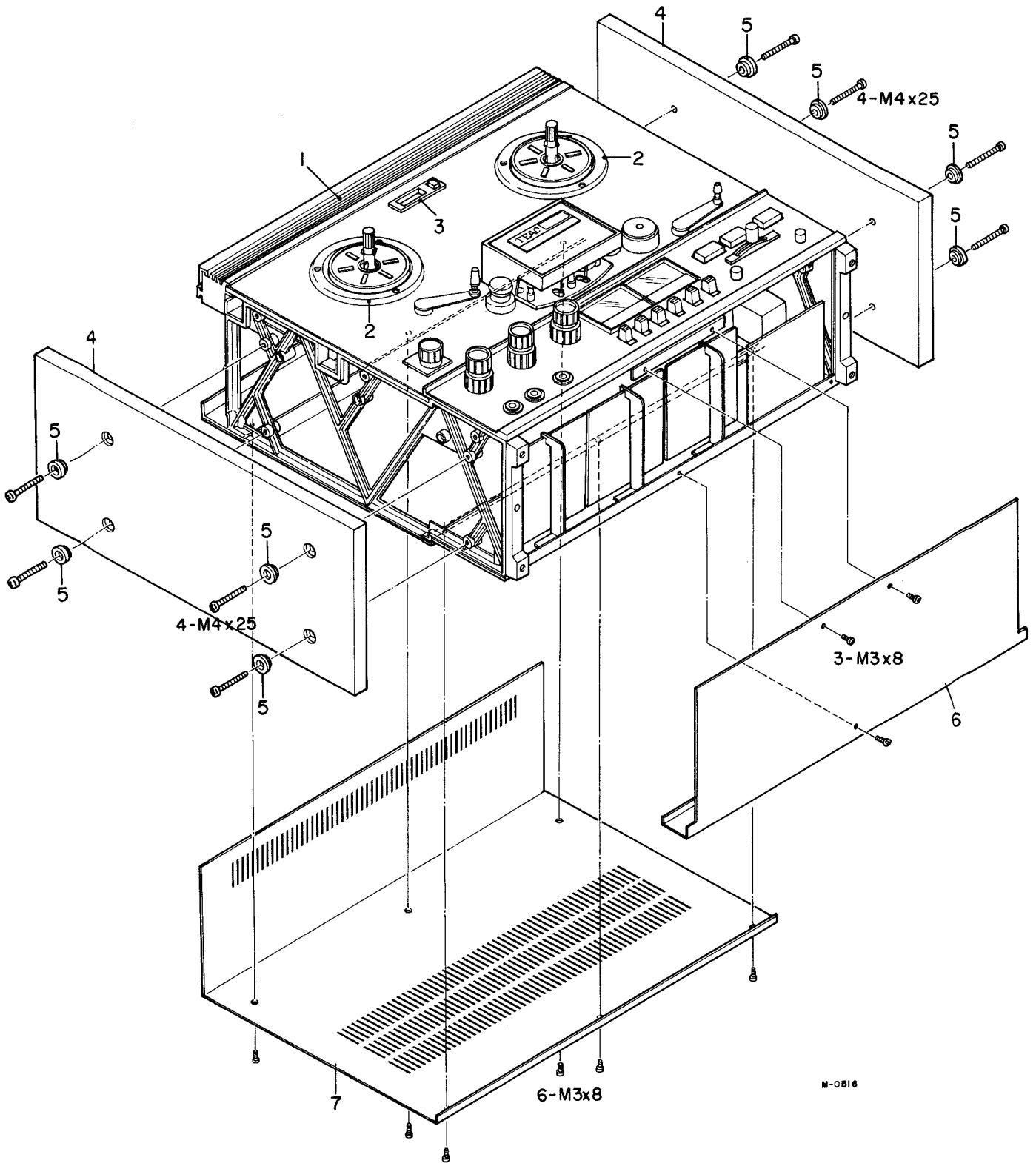

M-0518

TRIM PARTS

REF. TEAC NO. PARTS NO. DESCRIPTION	REVISION	
	1st	2nd
1-1 50112980 Grille, Top (Assy)		
1-2 50161940 Reel Protector		
1-3 50277020 Escutcheon, Counter (Cover)		
1-4 50288331 Wooden Plate		
1-5 50276930 Washer, Trim		
1-6 50287750 Cover, Bottom		
1-7 50288290 Cover, Rear		

CONTROL PANEL

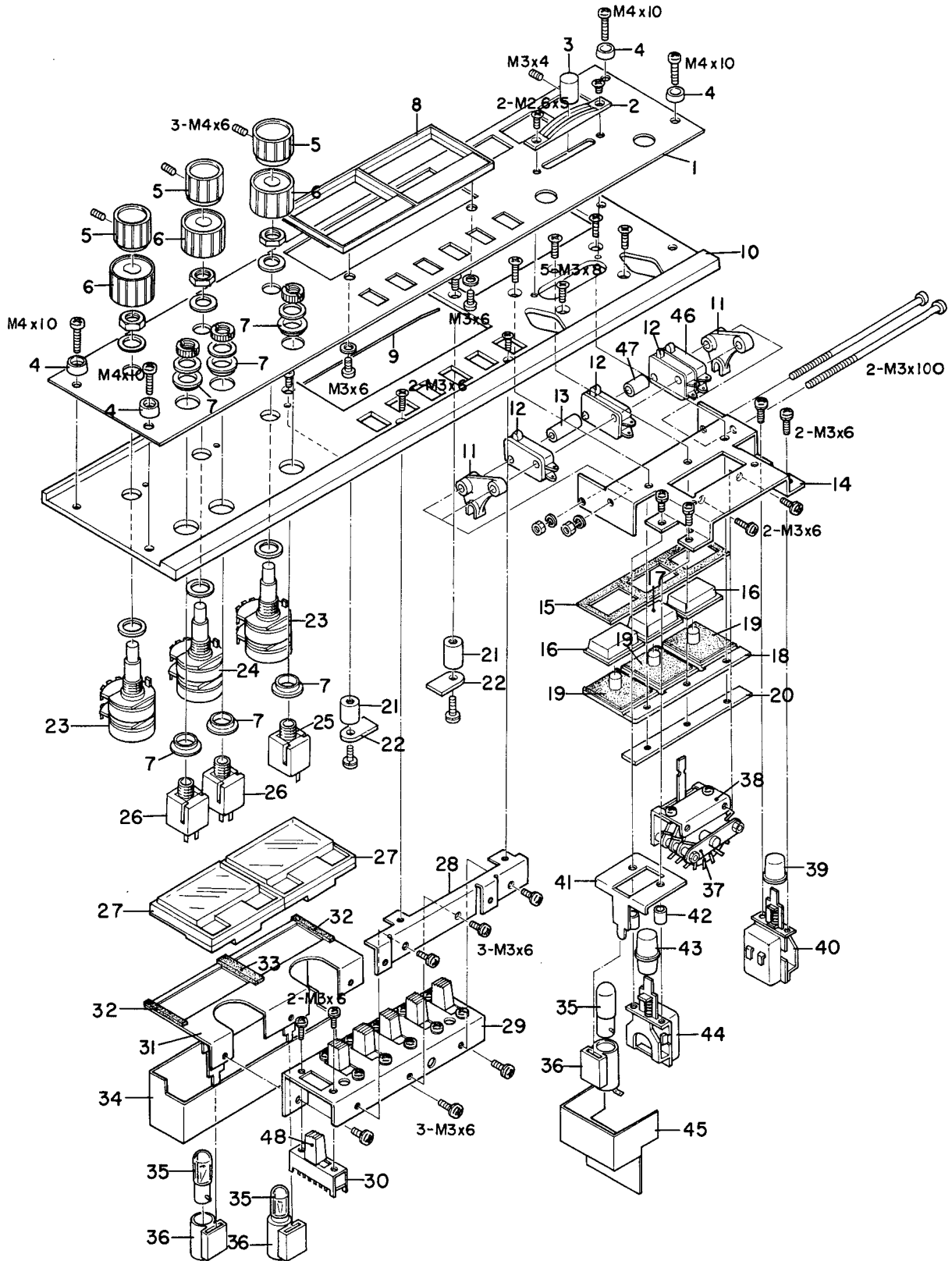

M-0517

CONTROL PANEL

REF. NO.	TEAC PARTS NO.	DESCRIPTION	REVISION	
			1st	2nd
2- 1	50236670	Panel, Ampl. Trim		
2- 2	50449900	Cover, Lever SW		
2- 3	50253470	Knob, D (Lever SW)		
2- 4	50277111	Washer, Trim		
2- 5	50253390	Knob, Upper		
2- 6	50253400	Knob, Lower		
2- 7	50272620	Washer, Insulator		
2- 8	50279830	Escutcheon, VU Meter		
2- 9	50331630	Clamp, Meter Escutcheon		
2-10	50236690	Panel, Ampl.		
2-11	50277540	Base Plate Holder		
2-12	50446090	SW, Micro (V-1A)		
2-13	50241121	Spacer, A (Micro SW)		
2-14	50277782	Plate, Control Base		
2-15	50277160	Rubber Protector		
2-16	50253210	Push Button, Control		
2-17	50253200	Push Button, Stop, B		
2-18	50253113	Push Button Base		
2-19	50277240	Rubber Plate Collar		
2-20	50277010	Plate, Control		
2-21	50236740	Spacer, VU Meter		
2-22	50236750	Plate, Meter Support		
2-23	50537100	VR, 2 Gang, 10k Ω \times 2 (MIC/OUTPUT)		
2-24	50537090	VR, 2 Gang, 100k Ω \times 2 (LINE)		
2-25	50432450	Jack, Phone, 3 cond. (Headphone)		
2-26	50430240	Jack, Phone, Single, (MIC)		
2-27	50581331	VU Meter		
2-28	50236730	Angle, Bottom Cover		
2-29	50236700	Plate, Slide SW, S		
2-30	50440000	SW, Slide		
2-31	50236710	Meter Retainer Assy, S		
2-32	50236130	Cushion, VU Meter, B		
2-33	50236120	Cushion, VU Meter, A		
2-34	50236761	Light Shield, S		
2-35	50414510	Lamp, Bayonet Type (8V)		
2-36	50415250	Socket, Lamp		
2-37	50442350	SW, Rotary (Lever Type)		
2-38	50277771	Plate, Rotary SW		
2-39	50253120	Push Button, A (Black)		
2-40	50443210	SW, Push, POWER (Lock)		
2-41	50235960	Bracket, Lamp Holder		
2-42	50235970	Spacer, Record SW		
2-43	50235950	Push Button, Record (Red)		
2-44	50443410	SW, Push, RECORD (Non Lock)		
2-45	50235981	Light Shield, Record Lamp		
2-46	50446180	SW, Micro (V-1A44)		
2-47	50241950	Spacer, B (Micro SW)		
2-48	50279991	Cap, Slide SW		

REAR PANEL

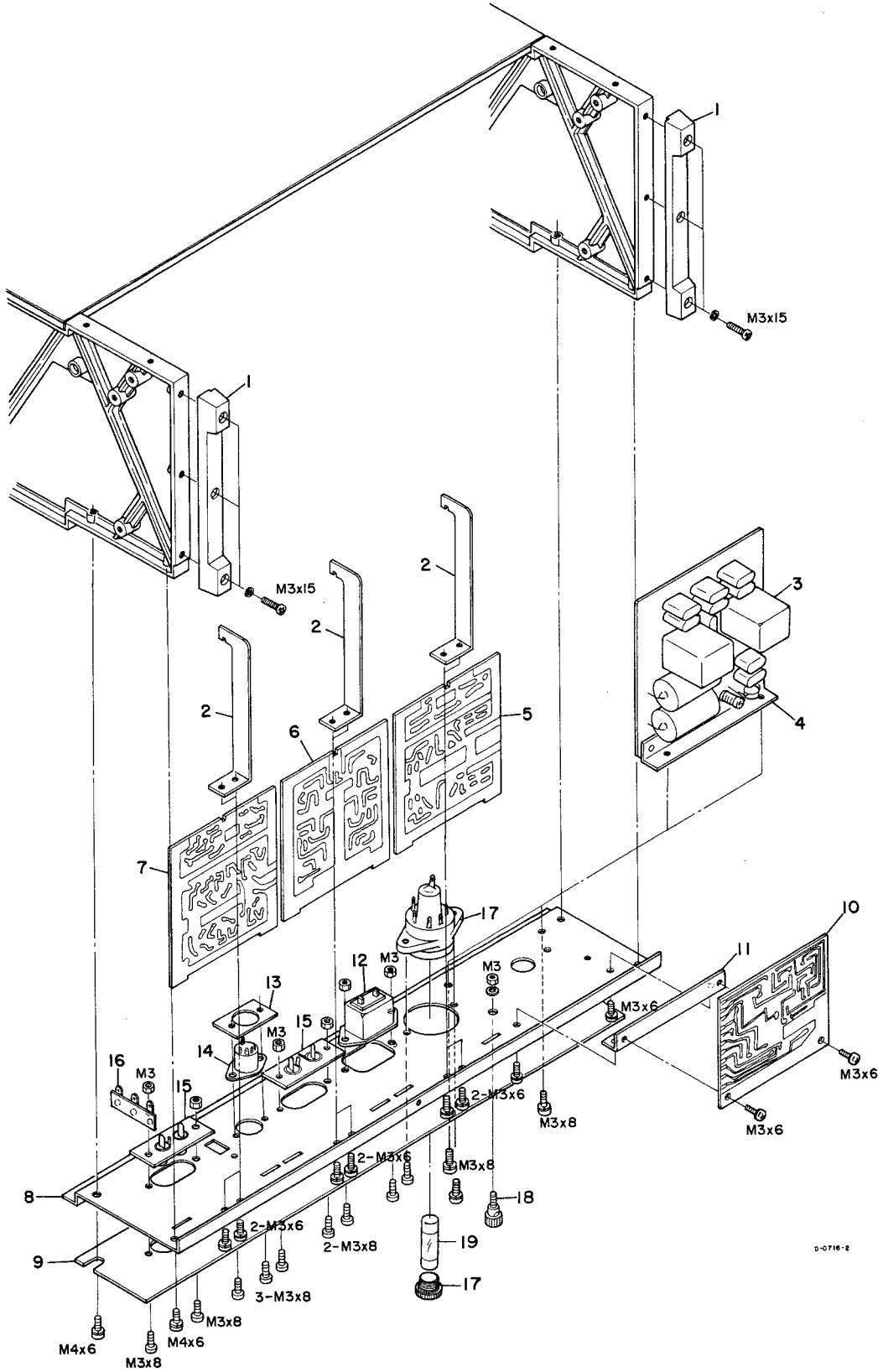

REAR PANEL

REF. NO.	TEAC PARTS NO.	DESCRIPTION	REVISION	
			1st	2nd
3- 1	50277980	Leg, Case		
3- 2	50233760	Plate, PC Board		
3- 3	50505170	PC Board Assy, Control Relay		
3- 4	50276850	Angle, B		
3- 5	50505210	PC Board Assy, Record and Meter Ampl.		
3- 6	50505150	PC Board Assy, Line and Phone Ampl.		
3- 7	50505160	PC Board Assy, Mic and PB EQ Ampl.		
3- 8	50234700	Chassis, Ampl.		
3- 9	50264621	Panel, Rear Trim		
3-10	50505220	PC Board Assy, Bias OSC		
3-11	50276840	Angle, A		
3-12	50432950	Socket, AC		
3-13	50233530	Plate, DIN Connector		
3-14	50430010	Connector, DIN		
3-15	50434631	Jack, Pin, 2P		
3-16	50452060	Terminal Strip, 1L-2P		
3-17	50412143	Voltage Selector, with Fuse		
3-18	50454071	Post, Grounding		
3-19	50411140	Fuse, 2A		

HEAD ASSY

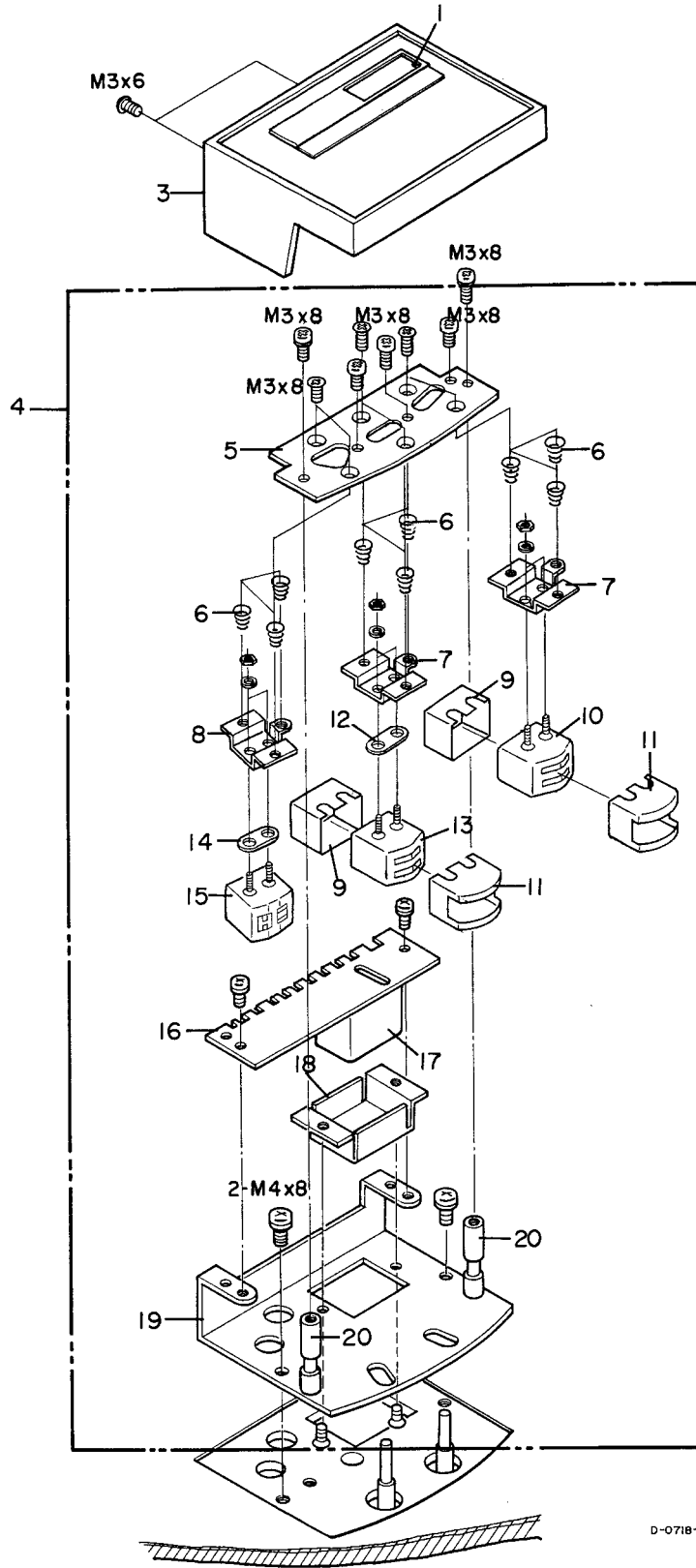

D-0718-2

HEAD ASSY

			REVISION	
REF. NO.	TEAC PARTS NO.	DESCRIPTION	1st	2nd
4- 1	50266510	Name Plate		
4- 3	50136550	Head Housing		
4- 4	50136600	Head Assy		
4- 5	50134400	Plate, Head Base		
4- 6	50220500	Spring, Head, B		
4- 7	50134370	Plate, ERP Head		
4- 8	50134420	Plate, E/R Head		
4- 9	50133900	Head Shield, B		
4-10	50669041	Head, PB		
4-11	50133891	Head Shield, A		
4-12	50134390	Spacer, Record Head		
4-13	50669041	Head, PB		
4-14	50134390	Spacer, Record Head		
4-15	50663410	Head, E/R		
4-16	50483080	PC Board, Head		
4-17	50610640	Relay, Head Selector		
4-18	50135780	Relay Holder		
4-19	50136560	Plate, Housing Base, C		
4-20	50182672	Guide Pin		

MAIN CHASSIS

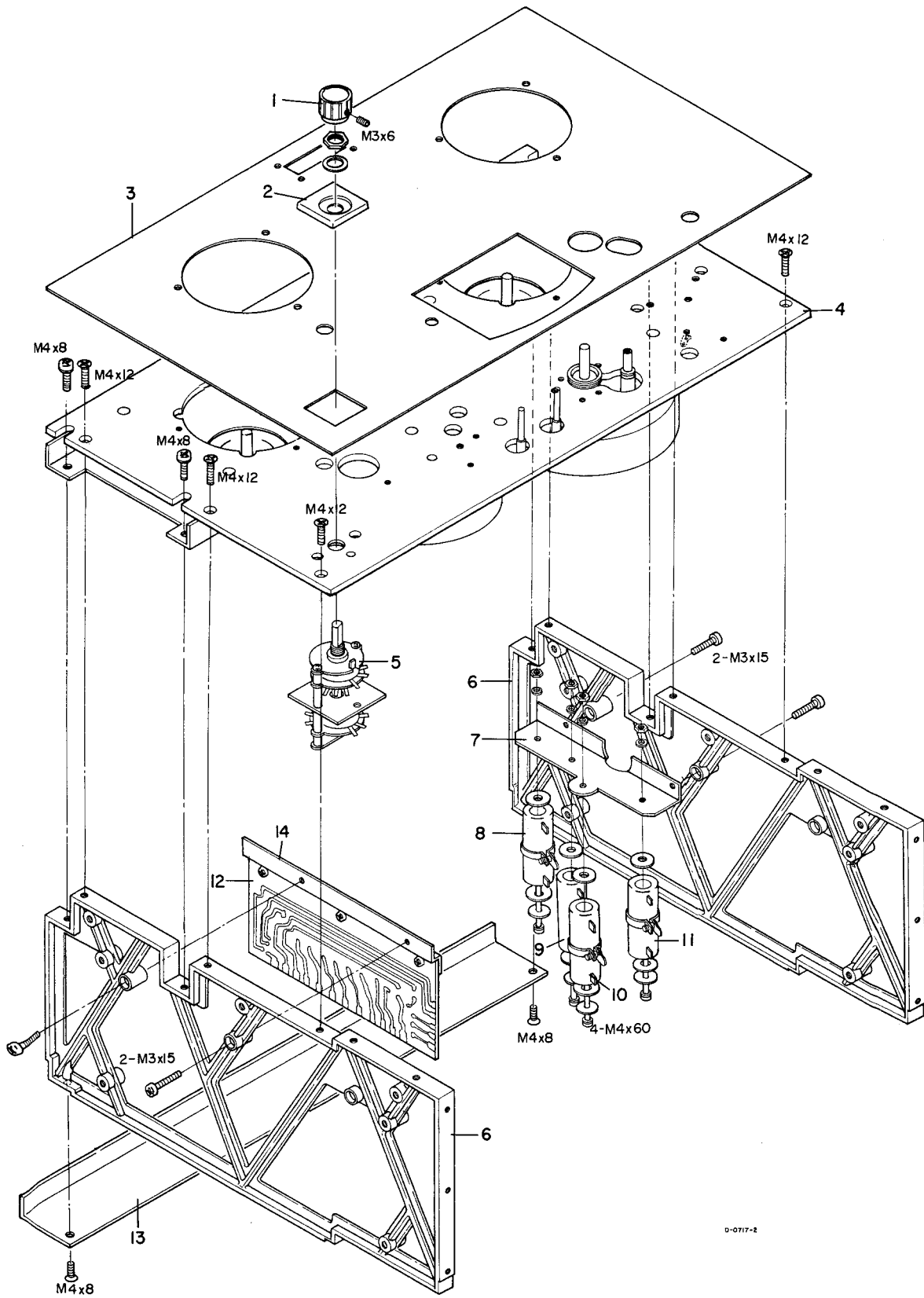

D-0717-2

MAIN CHASSIS

REF. NO.	TEAC PARTS NO.	DESCRIPTION	REVISION	
			1st	2nd
5- 1	50253390	Knob, Upper		
5- 2	50263171	Name Plate, Tape Speed		
5- 3	50112662	Panel, Trim		
5- 4	50117250	Panel, Chassis		
5- 5	50442360	SW, Rotary		
5- 6	50112712	Frame, Side		
5- 7	50330110	Plate, Resistor		
5- 8	50524321	Resistor, Wire Wound 500Ω 20HA		
5- 9	50522310	Resistor, Wire Wound 100Ω 20H		
5-10	50522210	Resistor, Wire Wound 50Ω 20HA		
5-11	50524201	Resistor, Wire Wound 100Ω 20HA		
5-12	50490491	PC Board Assy, Reverse		
5-13	50235311	Angle, Rear Cover		
5-14	50330840	Angle, PC Board, A		

LEFT TENSION ARM

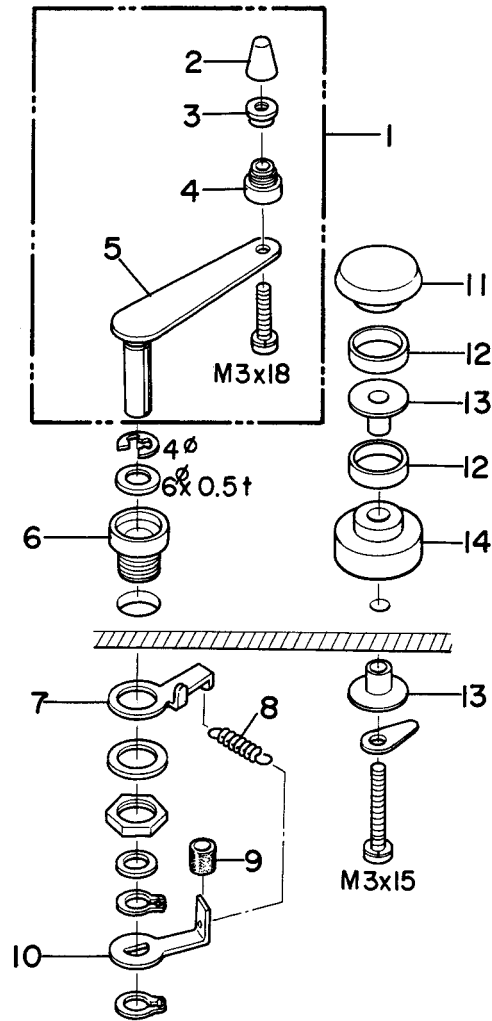

M-0519

			REVISION	
REF. NO.	TEAC PARTS NO.	DESCRIPTION	1st	2nd
6- 1	50180560	Tension Arm Assy, Left		
6- 2	50134360	Cap, Guide		
6- 3	50182780	Guide, C		
6- 4	50182770	Guide, D		
6- 5	50182821	Tension Arm, B (Left)		
6- 6	50182800	Bushing, Arm, B		
6- 7	50276870	Hook, Spring, Left		
6- 8	50221110	Spring, B, Tension Arm L		
6- 9	50276990	Collar, Rubber		
6-10	50182750	Limit Stop, Left		
6-11	50123911	Cap, Guide Ling		
6-12	50183871	Ring, Guide		
6-13	50183860	Post, Sensing		
6-14	50183880	Guide Ring Base		

RIGHT TENSION ARM

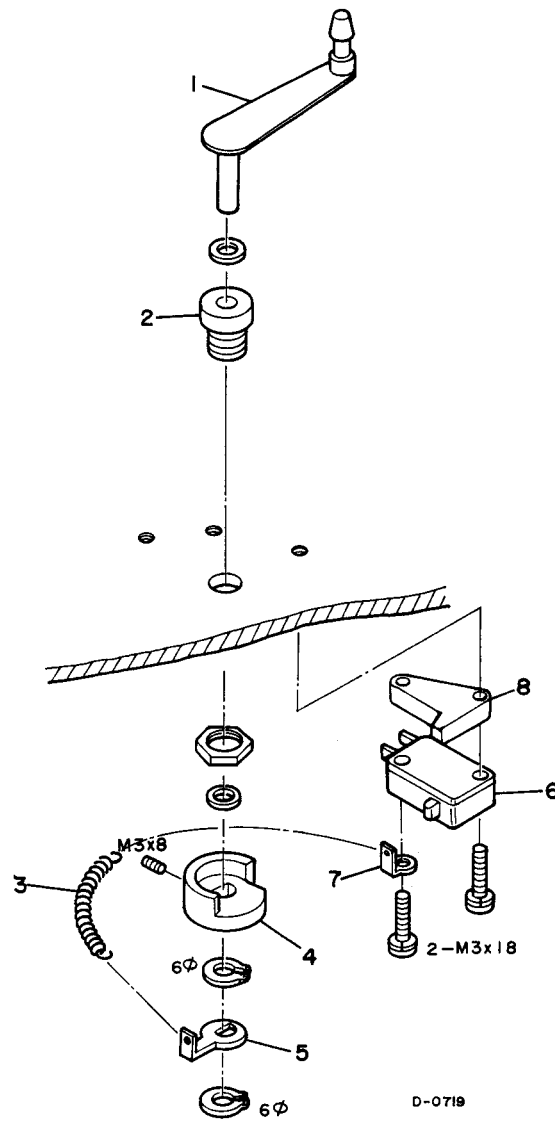

REF. NO.	TEAC PARTS NO.	DESCRIPTION	REVISION	
			1st	2nd
7-1	50180432	Tension Arm Assy, Right		
7-2	50182701	Bushing, Arm, A		
7-3	50221122	Spring, C, Tension Arm R		
7-4	50182990	Drum, Tension Arm		
7-5	50276860	Hook, Spring, Right		
7-6	50446180	SW, Micro (V-1A44)		
7-7		Lug, Spring Mounting		
7-8	50182730	Limit Stop, Right		

REEL MOTOR ASSY

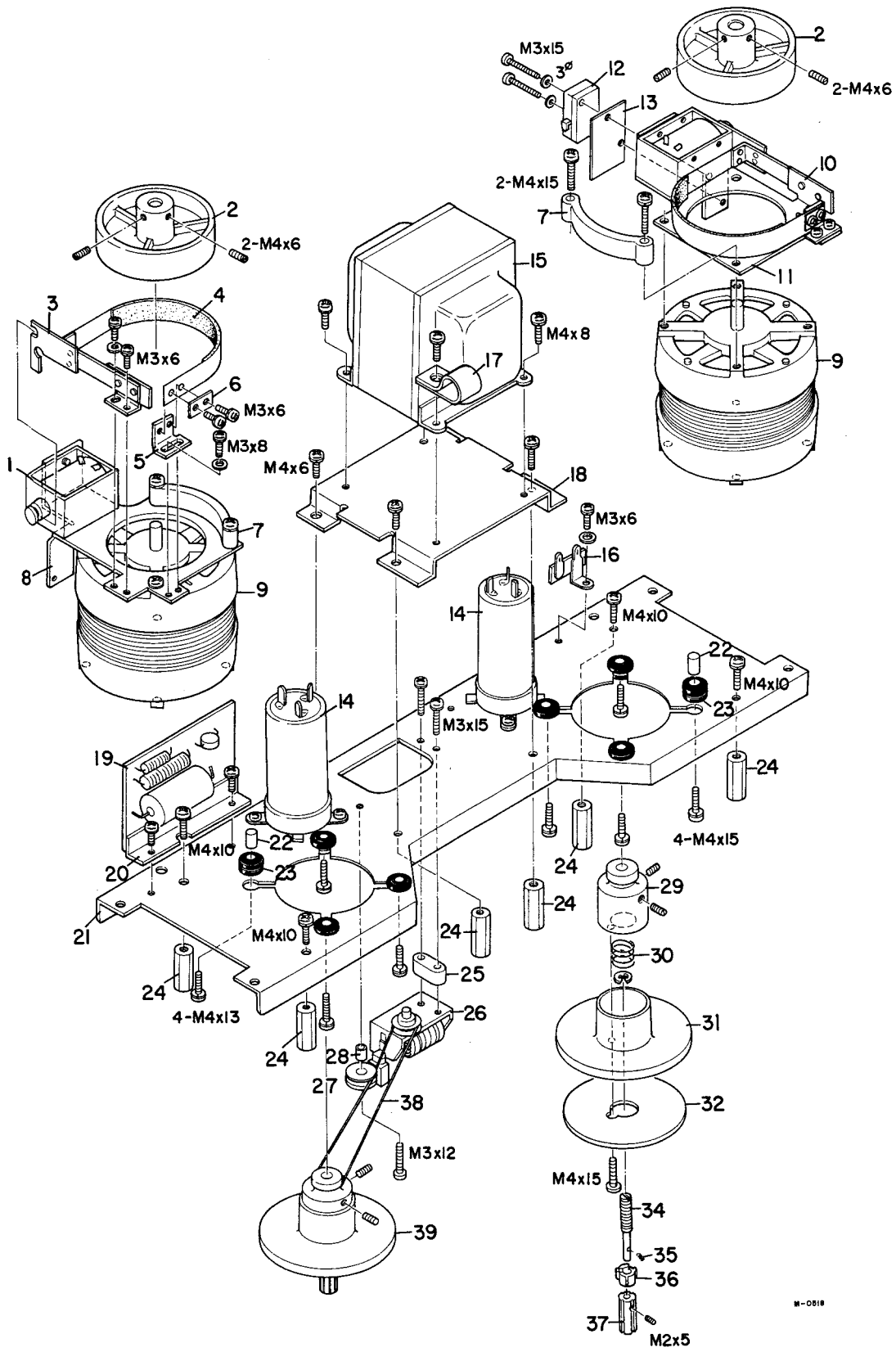

M-0818

REEL MOTOR ASSY

REF. NO.	TEAC PARTS NO.	DESCRIPTION	REVISION	
			1st	2nd
8- 1	50616370	Solenoid, Brake		
8- 2	50173560	Drum, Brake		
8- 3	50170143	Brake Band Assy, B		
8- 4	50171382	Felt, Brake		
8- 5	50170160	Angle, Band		
8- 6	50170150	Plate, Band Pressure		
8- 7	50172550	Brake Retainer		
8- 8	50172612	Plate, Reel Motor, B		
8- 9	50702251	Motor, Reel		
8-10	50170182	Brake Band Assy, A		
8-11	50172602	Plate, Reel Motor, A		
8-12	50446180	SW, Micro, V-1A44		
8-13	50173530	Insulator Plate		
8-14	50545660	Cap., MP 3+1 μ F/AC 250V		
8-15	50562350	Transformer, Power		
	50562360	Transformer, Power		
8-16	50452080	Terminal Strip, 1L-1P		
8-17	50276280	Clamp, Wire (Large)		
8-18	50233751	Plate, Power Transformer		
8-19	50500500	PC Board Assy, Rectifier		
8-20	50233930	Angle, PC Board, B		
8-21	50233922	Chassis, Reel Motor		
8-22	50162760	Spacer, Rubber Cushion		
8-23	50162960	Cushion, Rubber, B		
8-24	50161951	Stand-off, Reel Motor		
8-25	50276950	Spacer, Counter		
8-26	50585090	Counter		
8-27	50162940	Pulley, Counter Relay		
8-28	50163100	Shaft, Pulley		
8-29	50163301	Shaft, Reel		
8-30	50221650	Spring, Height Adjusting		
8-31	50163291	Reel Table		
8-32	50163340	Mat, Reel Table		
8-33	50213610	Screw, Reel Height Adjusting		
8-34	50163331	Shaft, Reel Lock, B		
8-35	50221610	Spring, Slip		
8-36	50163090	Reel Lock		
8-37	50163321	Knob, Reel Lock, B		
8-38	50276940	Belt, Counter		
8-39	50160331	Reel Table Assy		

CAPSTAN DRIVE ASSY

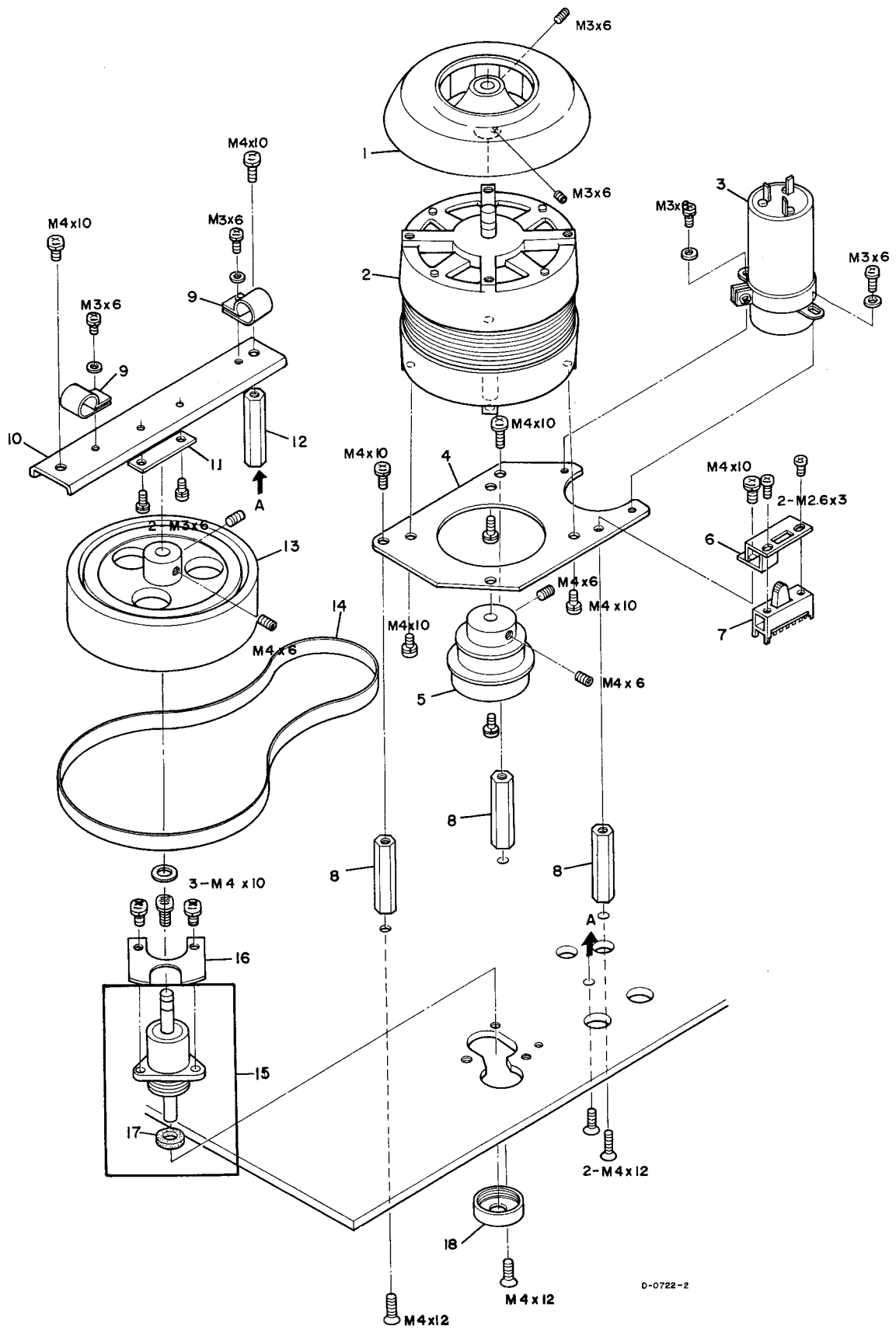

D-0722-2

CAPSTAN DRIVE ASSY

REF. NO.	TEAC PARTS NO.	DESCRIPTION	REVISION	
			1st	2nd
9- 1	50123980	Fan		
9- 2	50701343	Motor, Capstan		
9- 3	50545650	Cap., MP 2+0.8 μ F/250V		
9- 4	50123870	Plate, Capstan Motor		
9- 5	50124003	Pulley, Motor (50Hz/60Hz)		
9- 6	50276910	Bracket, Slide SW		
9- 7	50444170	SW, Slide		
9- 8	50123850	Stand-off, Capstan		
9- 9	50276280	Clamp, Wire		
9-10	50277151	Angle, Thrust		
9-11	50277230	Plate, Thrust		
9-12	50123860	Stand-off, Flywheel		
9-13	50123801	Flywheel, Capstan		
9-14	50123830	Belt, Capstan		
9-15	50120440	Capstan Assy		
9-16	50142190	Plate, Arm Support		
9-17	50123900	Sponge Oiler		
9-18	50123971	Cap, Dust		

LIFTER AND PINCH ROLLER

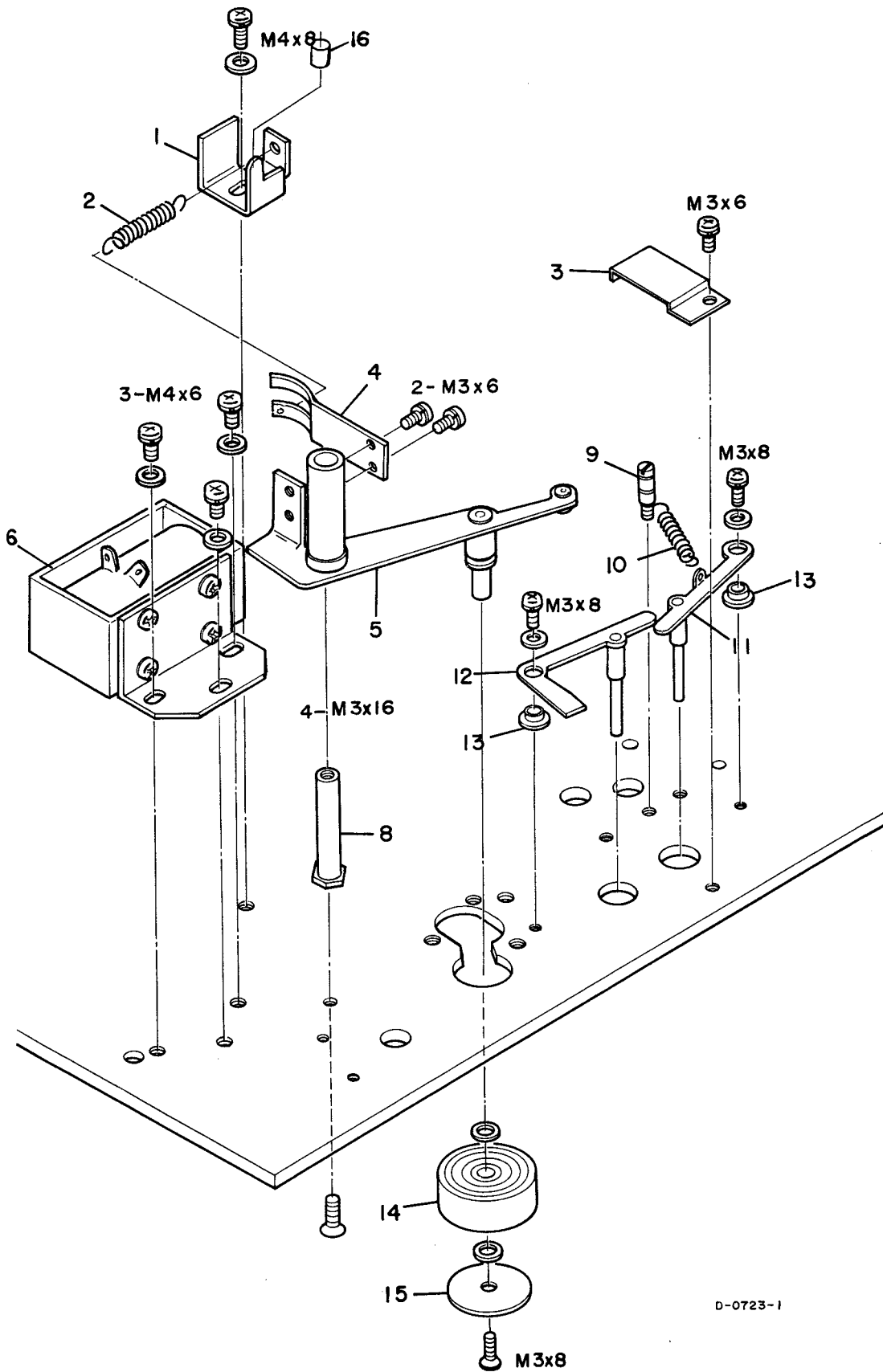

D-0723-1

LIFTER AND PINCH ROLLER

REF. NO.	TEAC PARTS NO.	DESCRIPTION	REVISION	
			1st	2nd
10- 1	50141841	Limit Stop, Pinch Roller		
10- 2	50220441	Spring, Return		
10- 3	50152453	Plate, Lifter		
10- 4	50221151	Spring Pressure		
10- 5	50140235	Arm, Pinch Roller (Assy)		
10- 6	50616360	Solenoid, Pinch Roller (Assy)		
10- 8	50141821	Shaft, Roller Arm		
10- 9	50123140	Pin, Lifter Spring		
10-10	50221100	Spring, Lifter, A		
10-11	50150251	Arm, Lifter (Assy), B		
10-12	50150241	Arm, Lifter (Assy), A		
10-13	50152501	Shaft, Lifter Arm		
10-14	50141751	Pinch Roller		
10-15	50141760	Cap, Pinch Roller		
10-16	50275690	Cushion, Rubber		

STANDARD ACCESSORIES

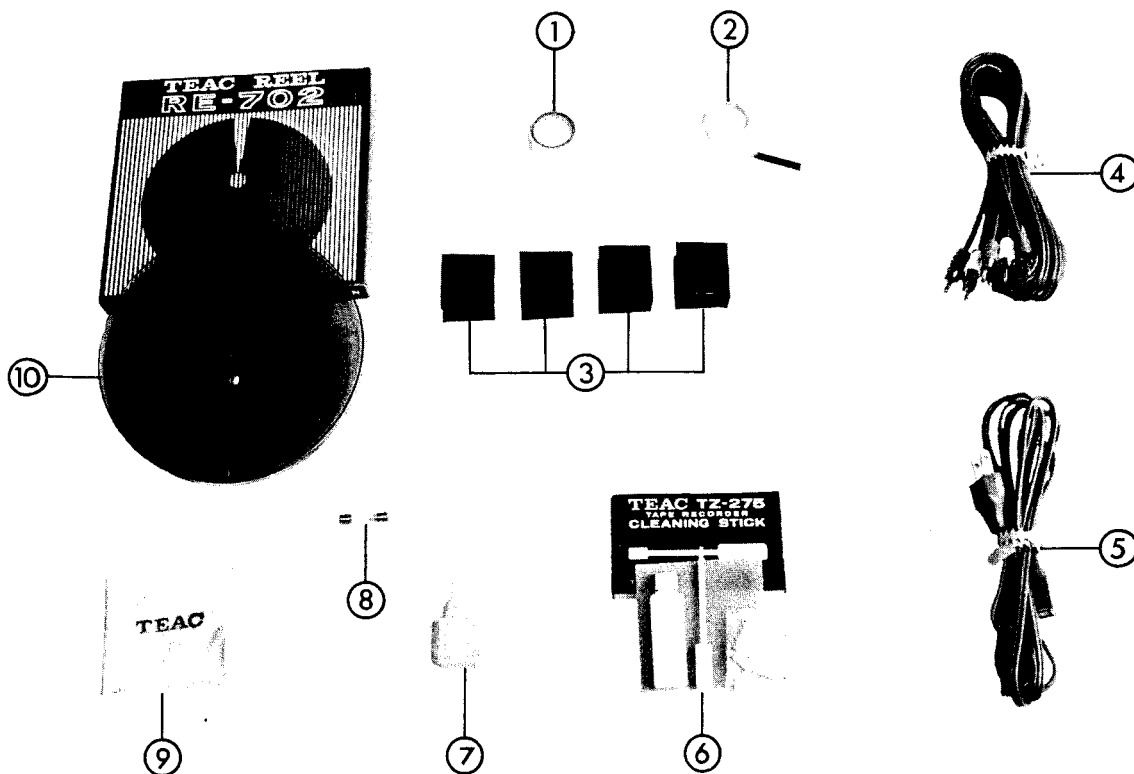

REF. NO.	TEAC PARTS NO.	DESCRIPTION	REVISION	
			1st	2nd
11- 1	50629620	Splicing Tape		
11- 2	50272880	Sensing Tape		
11- 3	50276971	Rubber Feet (for Horizontal Use), ×4		
11- 4	50471250	Input Output Connection Cords, ×2		
11- 5	50470772	AC Power Cord		
11- 6	57100300	Cleaning Stick (TZ-275)		
11- 7	50291860	Oil and Applicator		
11- 8	50411140	Fuse, 2A		
11- 9	50291350	Silicone Cloth		
11-10	50850081	Empty Reel, 7 inch, Small Hub (RE-702)		

PRINTED CIRCUIT BOARD PARTS LIST**A-1250S**

REPLACEMENT INFORMATION

Replacement parts are available through your nearest TEAC dealer or directly from the TEAC office.

Changes are constantly being made to make TEAC products better and more reliable.

Therefore, when ordering parts, always include the following information:

<i>MODEL</i>	<i>SERIAL NO.</i>	<i>REF.NO.</i>	<i>PARTS NO.</i>	<i>DESCRIPTION</i>
--------------	-------------------	----------------	------------------	--------------------

TEAC CORPORATION

MIC AND PLAYBACK EQ. AMPLIFIER

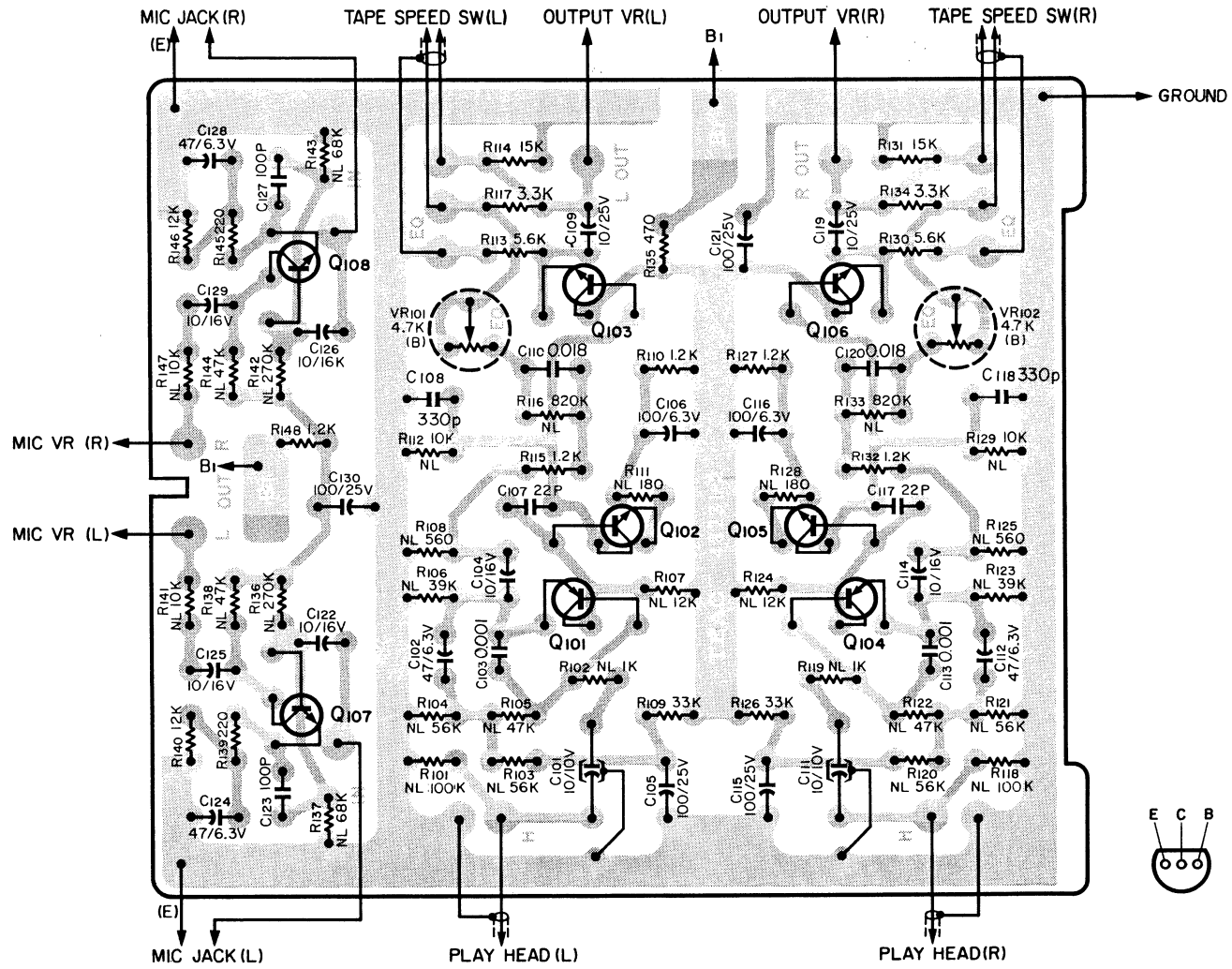

N-0206-1

MIC AND PLAYBACK EQ. AMPLIFIER

CIRCUIT REF.NO.	TEAC PARTS NO.	DESCRIPTION	REVISION		
			1st	2nd	3rd
	50505160	PC Board Assy			
	50482312	PC Board			
		SILICON TRANSISTORS			
Q101/104	50424340	2SC1000(BL)			
Q102/105	50423650	2SA494(Y)			
Q103/106	50423830	2SC536(F)			
Q107/108	50423870	2SC693(G)			
		CARBON RESISTORS			
		<i>ALL RESISTORS IN OHMS, 10% TOLERANCE, 1/4 WATTS UNLESS OTHERWISE NOTED.</i>			
R101/118	50515640	100k			
R102/119	50515340	1k			
R103/120	50515610	56k			
R104/121	50515610	56k			
R105/122	50515590	47k			
R106/123	50515580	39k			
R107/124	50515500	12k			
R108/125	50515310	560			
R109/126	50515570	33k			
R110/127	50515350	1.2k			
R111/128	50515250	180			
R112/129	50515490	10k			
R113/130	50515460	5.6k			
R114/131	50515510	15k			
R115/132	50515350	1.2k			
R116/133	50515770	820k			
R117/134	50515410	3.3k 5%			
R135	50515300	470			
R136/142	50515700	270k			
R137/143	50515620	68k			
R138/144	50515590	47k			
R139/145	50515260	220			
R140/146	50515500	12k			
R141/147	50515490	10k			
R148	50515350	1.2k			
		TRIMMER RESISTOR			
VR101/102	50533460	4.7k Ω B 10 ϕ			
		CAPACITORS			
		<i>ALL CAPACITORS IN MICRO FARADS UNLESS OTHERWISE NOTED.</i>			
C101/111	50546010	Tantalum 10 10V			
C102/112	50554030	Elec. 47 6.3V			
C103/113	50548320	Mylar 0.001 50V			
C104/114	50555650	Elec. 10 16V			
C105/115	50554170	Elec. 100 25V			
C106/116	50554230	Elec. 100 6.3V			
C107/117	50543330	High Q 22pF 50V			
C108/118	50543340	High Q 330pF 50V			
C109/119	50554040	Elec. 10 25V			
C110/120	50548550	Mylar 0.018 50V			
C121	50554170	Elec. 100 25V			
C122/126	50554050	Elec. 10 16V			
C123/127	50543400	High Q 100p 50V			
C124/128	50554030	Elec. 47 6.3V			
C125/129	50554050	Elec. 10 16V			
C130	50554170	Elec. 100 25V			

LINE OUT AND PHONE AMPLIFIER

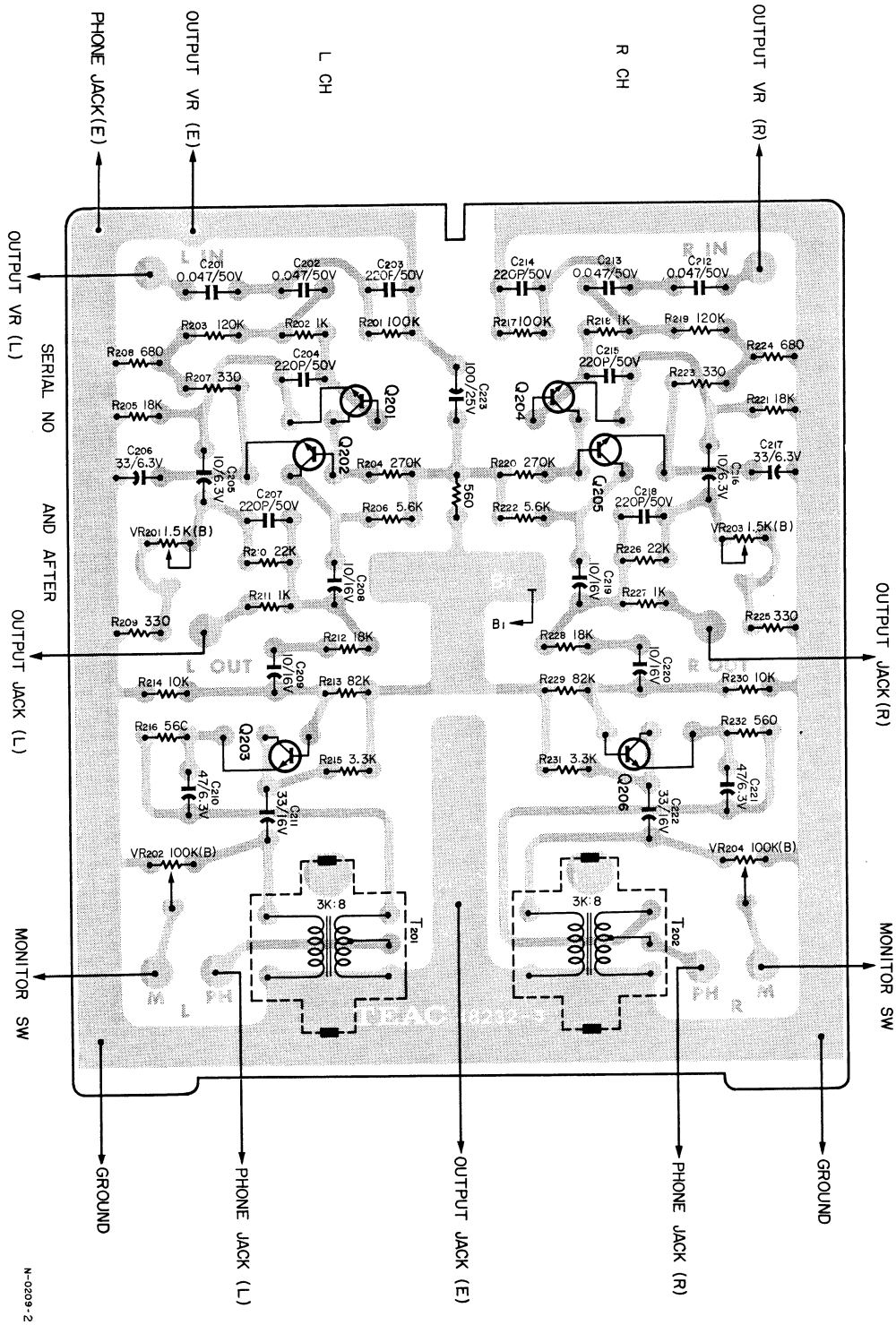

N-0209-2

LINE OUT AND PHONE AMPLIFIER

CIRCUIT REF.NO. TEAC PARTS NO. DESCRIPTION		REVISION		
		1st	2nd	3rd
50490520 PC Board Assy				
50482323 PC Board				
SILICON TRANSISTORS				
Q201/204	50423300 2SC693(F)			
Q202/205	50423310 2SC536(E)			
Q203/206	50423310 2SC536(E)			
CARBON RESISTORS				
<i>ALL RESISTORS IN OHMS, 10% TOLERANCE, 1/4 WATT UNLESS OTHERWISE NOTED.</i>				
R201/217	50515640 100k			
R202/218	50515340 1k			
R203/219	50515650 120k			
R204/220	50515700 270k			
R205/221	50515520 18k			
R206/222	50515460 5.6k			
R207/223	50515280 330			
R208/224	50515320 680			
R209/225	50515280 330			
R210/226	50515540 22k			
R211/227	50515340 1k			
R212/228	50515520 18k			
R213/229	50515630 82k			
R214/230	50515490 10k			
R215/231	50515410 3.3k			
R216/232	50515310 560			
R233	50515310 560			
TRIMMER RESISTORS				
VR201/203	50533450 1.5kΩ B 10φ			
VR202/204	50533490 100kΩ B 10φ			
CAPACITORS				
<i>ALL CAPACITORS IN MICRO FARADS UNLESS OTHERWISE NOTED.</i>				
C201/213	50548270 Mylar 0.047 50V			
C202/213	50548270 Mylar 0.047 50V			
C203/214	50548320 High Q 220pF 50V			
C204/215	50543420 High Q 220pF 50V			
C205/216	50554250 Elec. 10 6.3V			
C206/217	50554240 Elec. 33 6.3V			
C207/218	50543420 High Q 220pF 50V			
C208/219	50554050 Elec. 10 16V			
C209/220	50554050 Elec. 10 16V			
C210/221	50554030 Elec. 47 6.3V			
C211/222	50554260 Elec. 33 16V			
C223	50554170 Elec. 100 25V			
TRANSFORMER				
T201/202	50562141 Transformer, Headphone 3kΩ:8Ω			

METER AND REC. EQ. AMPLIFIER

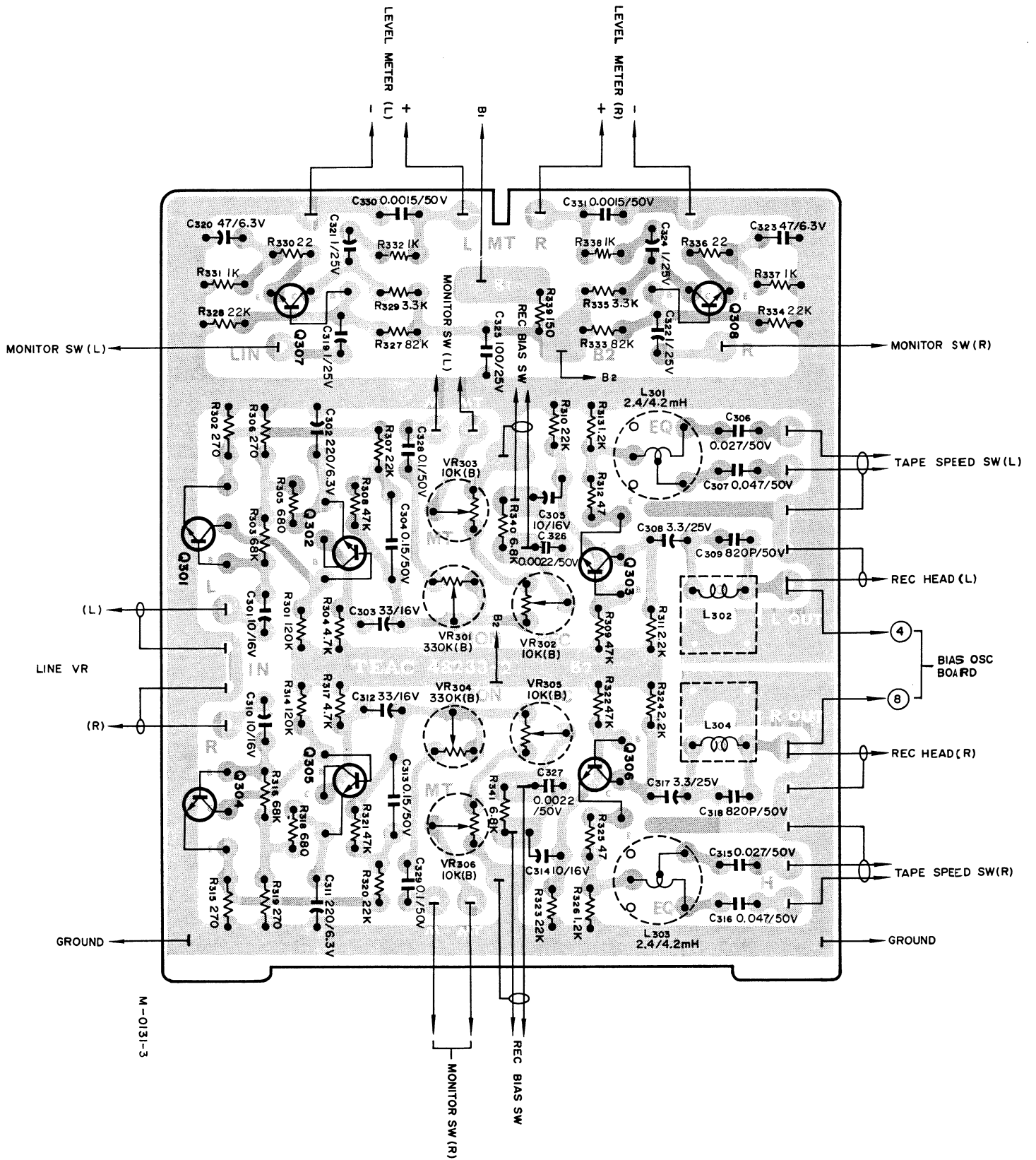

METER AND REC. EQ. AMPLIFIER

CIRCUIT REF.NO.	TEAC PARTS NO.	DESCRIPTION	REVISION		
			1st	2nd	3rd
	50490530	PC Board Assy			
	50482332	PC Board			
		SILICON TRANSISTORS			
Q301/304	50423870	2SC693(G)			
Q302/305	50423830	2SC536(F)			
Q303/306	50423830	2SC536(F)			
Q307/308	50423830	2SC536(F)			
		CARBON RESISTORS			
		<i>ALL RESISTORS IN OHMS, 10% TOLERANCE 1/4 WATT UNLESS OTHERWISE NOTED.</i>			
R301/314	50515650	120k			
R302/315	50515270	270			
R303/316	50515620	68k			
R304/317	50515460	4.7k			
R305/318	50515320	680			
R306/319	50515270	270			
R307/320	50515540	22k			
R308/321	50515590	47k			
R309/322	50515590	47k			
R310/323	50515540	22k			
R311/324	50515380	2.2k			
R312/325	50515170	47			
R313/326	50515350	1.2k			
R327/333	50515630	82k			
R328/334	50515540	22k			
R329/335	50515410	3.3k			
R330/336	50515130	22			
R331/337	50515340	1k			
R332/338	50515340	1k			
R339	50515240	150			
R340/341	50515490	6.8k			
		TRIMMER RESISTORS			
VR301/304	50533670	330kΩ B 10 ϕ			
VR302/305	50533480	10kΩ B 10 ϕ			
VR303/306	50533480	10kΩ B 10 ϕ			
		CAPACITORS			
		<i>ALL CAPACITORS IN MICRO FARADS UNLESS OTHERWISE NOTED.</i>			
C301/310	50554050	Elec. 10 16V			
C302/311	50554330	Elec. 220 6.3V			
C303/312	50554260	Elec. 33 16V			
C304/313	50548310	Mylar 0.15 50V			
C305/314	50554050	Elec. 10 16V			
C306/315	50548330	Mylar 0.027 50V			
C307/316	50548270	Mylar 0.047 50V			
C308/317	50549680	Elec. 3.3 25V			
C309/318	50543440	Polyst. 820pF 50V			
C319/322	50554670	Elec. 1 25V			
C320/323	50554030	Elec. 47 6.3V			
C321/324	50554670	Elec. 1 25V			
C325	50554170	Elec. 100 25V			
C326/327	50548450	Mylar 0.0022 50V			
C328/329	50548040	Mylar 0.1 50V			
C330/331	50548120	Mylar 0.0015 50V			
		COILS			
L301/303	50566370	Record Compensation 2.4 μ 4.2mH			
L302/304	50566300	Trap 3mH			

BIAS OSC. AND REC. RELAY

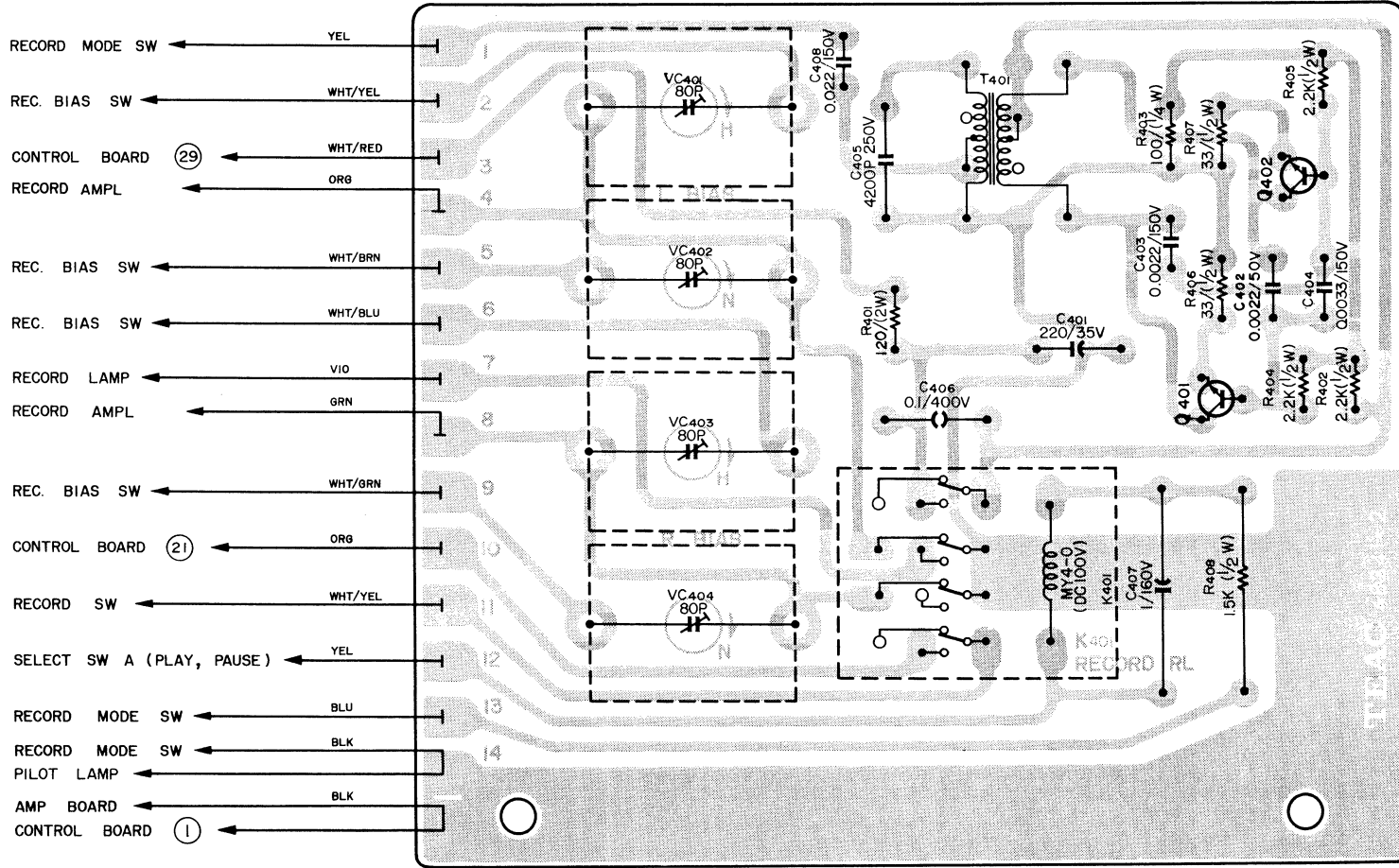

N-0224-2

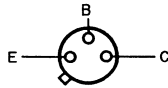

E : EMITTER
B : BASE
C : COLLECTOR

BIAS OSC. AND REC. RELAY

			REVISION	
CIRCUIT REF.NO.	TEAC PARTS NO.	DESCRIPTION	1st	2nd
	50505220	PC Board Assy		
	50482412	PC Board		
		SILICON TRANSISTOR		
Q401-402	50523850	2SC971, with Heat Sink		
		RESISTORS		
R401	50525380	Wire Wound 120Ω 2W		
R402	50514920	Carbon 2.2kΩ 1/2W		
R403	50515220	Carbon 100Ω 1/4W		
R404-405	50514920	Carbon 2.2kΩ 1/2W		
R406-407	50514990	Carbon 33Ω 1/2W		
R408	50514550	Carbon 1.5kΩ 1/2W		
		CAPACITORS		
C401	50554380	Elec. 220μF 35V		
C402-403	50548760	Mylar 0.0022μF 50V		
C404	50548810	Mylar 0.0033μF 50V		
C405	50544040	Mica 4200pF 250V		
C406	50549920	Mylar 0.1μF 400V		
C407	50553310	Elec. 1μF 160V		
C408	50548740	Mylar 0.022μF 150V		
		TRIMMER CAPACITORS		
VC401-402	50547070	80pF Max		
VC403-404	50547070	80pF Max		
		MISCELLANEOUS		
T401	50563170	Coil, Oscillator		
K401	50610730	Relay, 4T DC 100V		

CONTROL RELAY

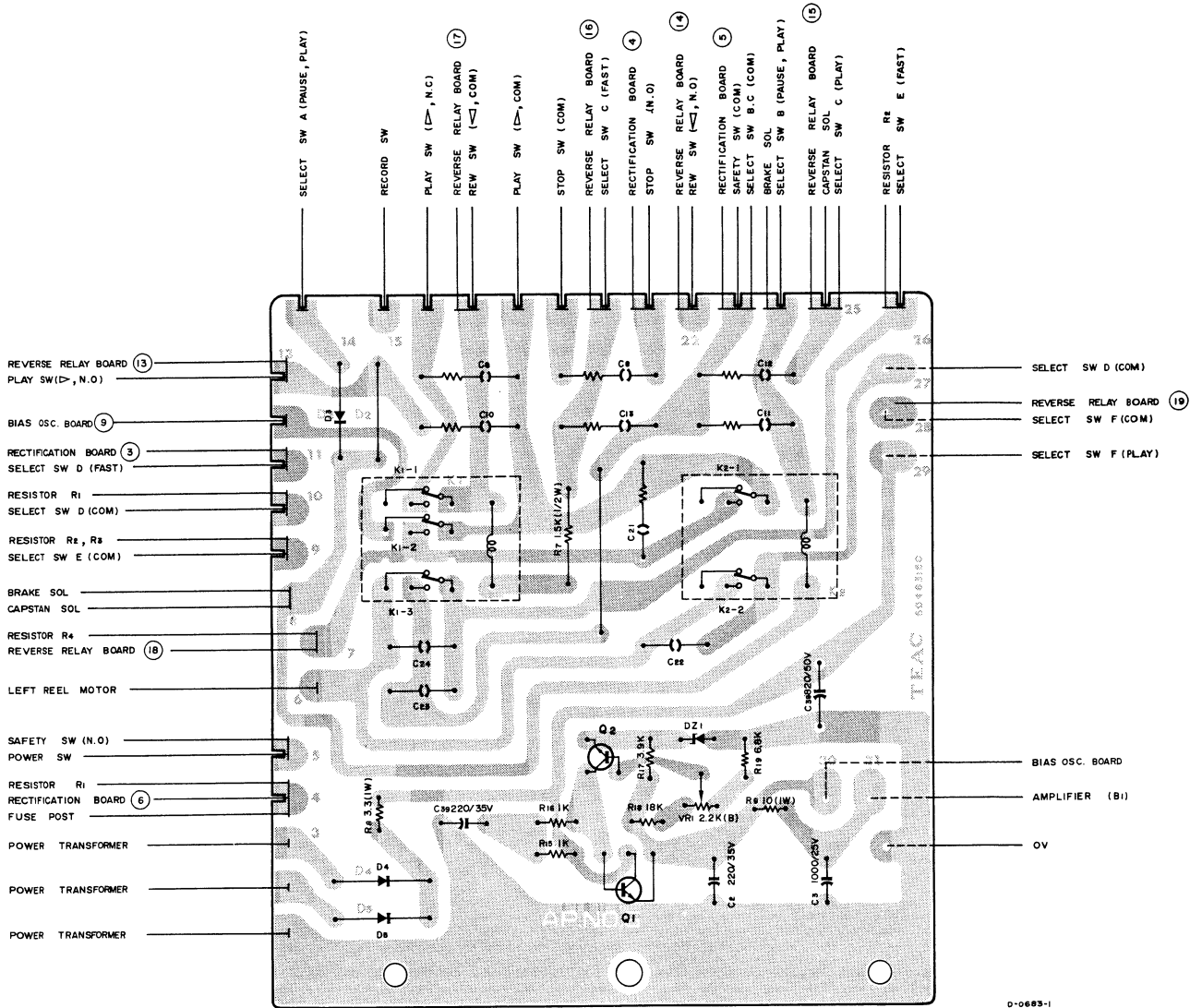

0-0683-1

CONTROL RELAY

CIRCUIT REF.NO. TEAC PARTS NO.		REVISION	
		1st	2nd
	50490230	PC Board Assy	
	50483151	PC Board	
	RELAYS		
K1	50610730	4T, DC 100V	
K2	50610750	2T, DC 100V	
	SILICON TRANSISTORS		
Q1	50424270	2SD317(P)	
Q2	50423510	2SC733(Y)	
	DIODES		
D4·5	50422360	FR2-06	
D3	50422380	FR2-10	
DZ1	50422580	O2Z 6.2A	
	RESISTORS		
R7	50574860	Carbon 1.5k Ω 1/2W	
R8	50525440	Wire Wound 3.3 Ω 1W	
R9	50525100	Wire Wound 10 Ω 1W	
R15·16	50515340	Carbon 1k Ω 1/4W	
R17	50515430	Carbon 3.9k Ω 1/4W	
R18	50515520	Carbon 18k Ω 1/4W	
R19	50515490	Carbon 6.8k Ω 1/4W	
	TRIMMER RESISTOR		
VR1	50533640	2.2k Ω B 10 ϕ	
	CAPACITORS		
C2	50554380	Elec. 220 μ F 35V	
C3	50554440	Elec. 1000 μ F 25V	
C8 ω 13	50529050	Spark Killer 0.1 μ F + 120 Ω 400V	
C21	50529050	Spark Killer 0.1 μ F + 120 Ω 400V	
C22·23·24	50549920	Mylar 0.1 μ F 400V	
C38	50557080	Elec. 820 μ F 50V	
C39	50554380	Elec. 220 μ F 35V	

REVERSE RELAY

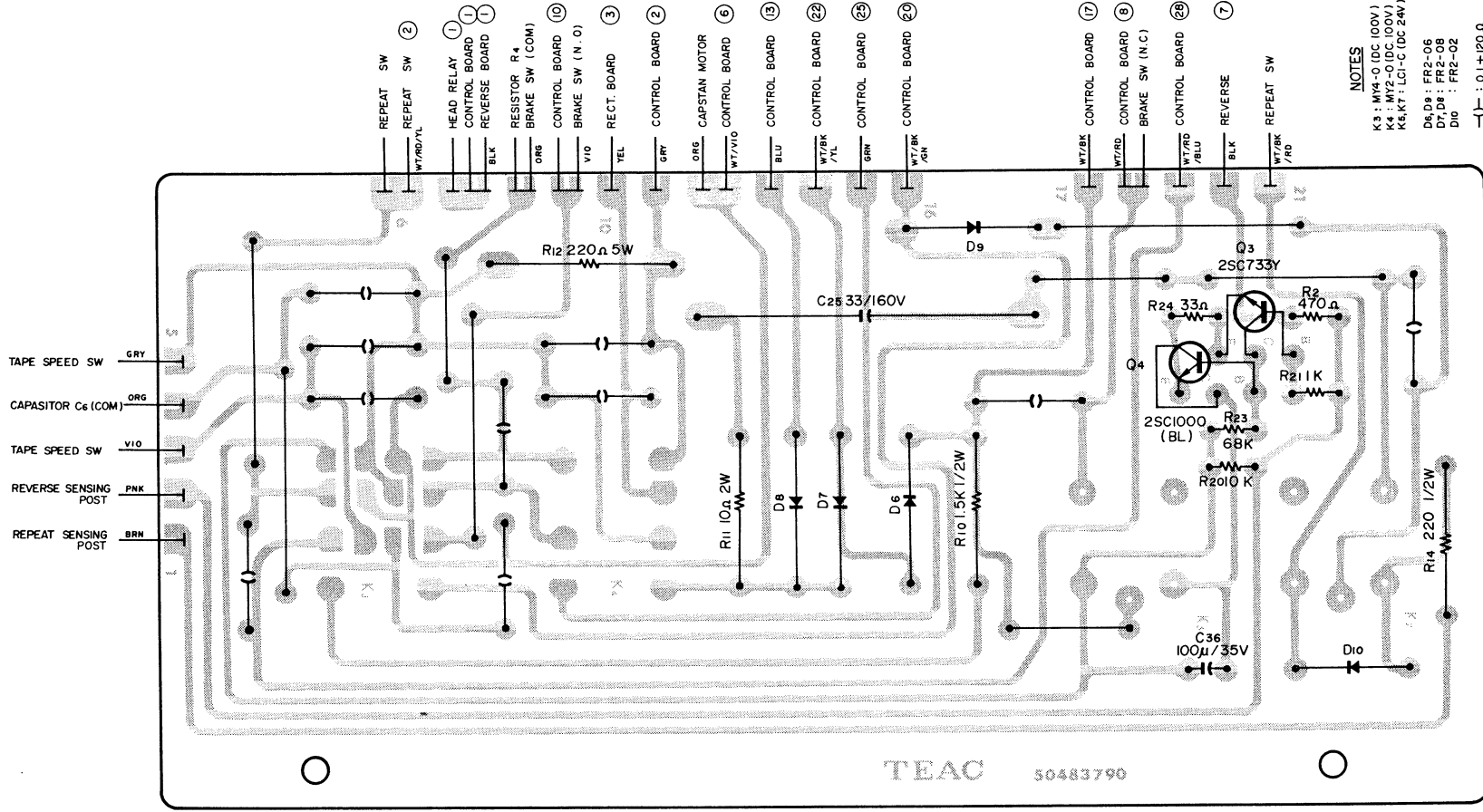

NOTES
 K₃ : MY4-O (DC 100V)
 K₄ : MY2-O (DC 100V)
 K₅, K₇ : LC1-C (DC 24V)
 D₆, D₉ : FR2-06
 D₇, D₈ : FR2-08
 D₁₀ : FR2-02
 (-) : 0.1+120 Ω

REVERSE RELAY

CIRCUIT REF.NO.	TEAC PARTS NO.	DESCRIPTION	REVISION	
			1st	2nd
	50490491	PC Board Assy		
	50483791	PC Board		
		RELAYS		
K3	50610730	4T, DC 100V		
K4	50610750	2T, DC 100V		
K5·7	50610800	1T, DC 24V		
		SILICON TRANSISTORS		
Q3	50423510	2SC733(Y)		
Q4	50424240	2SC1000(BL)		
		DIODES		
D6·9	50422360	FR2-06		
D7·8	50422370	FR2-08		
D10	50422340	FR2-02		
		RESISTORS		
R10	50574860	Wire Wound R-Type 1.5k Ω 1/2W		
R11	50525810	Wire Wound 10 Ω 2W		
R12	50526080	Wire Wound 220 Ω 5W		
R14	50574660	Wire Wound R-Type 220 Ω 1/2W		
R20	50515490	Carbon 10k Ω 1/4W		
R21	50515340	Carbon 1k Ω 1/4W		
R22	50515300	Carbon 470 Ω 1/4W		
R23	50515620	Carbon 68k Ω 1/4W		
R24	50515150	Carbon, ELR 33 Ω 1/4W		
		CAPACITORS		
C25	50555510	Elec. 33 μ F 160V		
C36	50554630	Elec. 100 μ F 35V		
	50529050	Spark Killer 0.1 μ F + 120 Ω 400V		

RECTIFIER

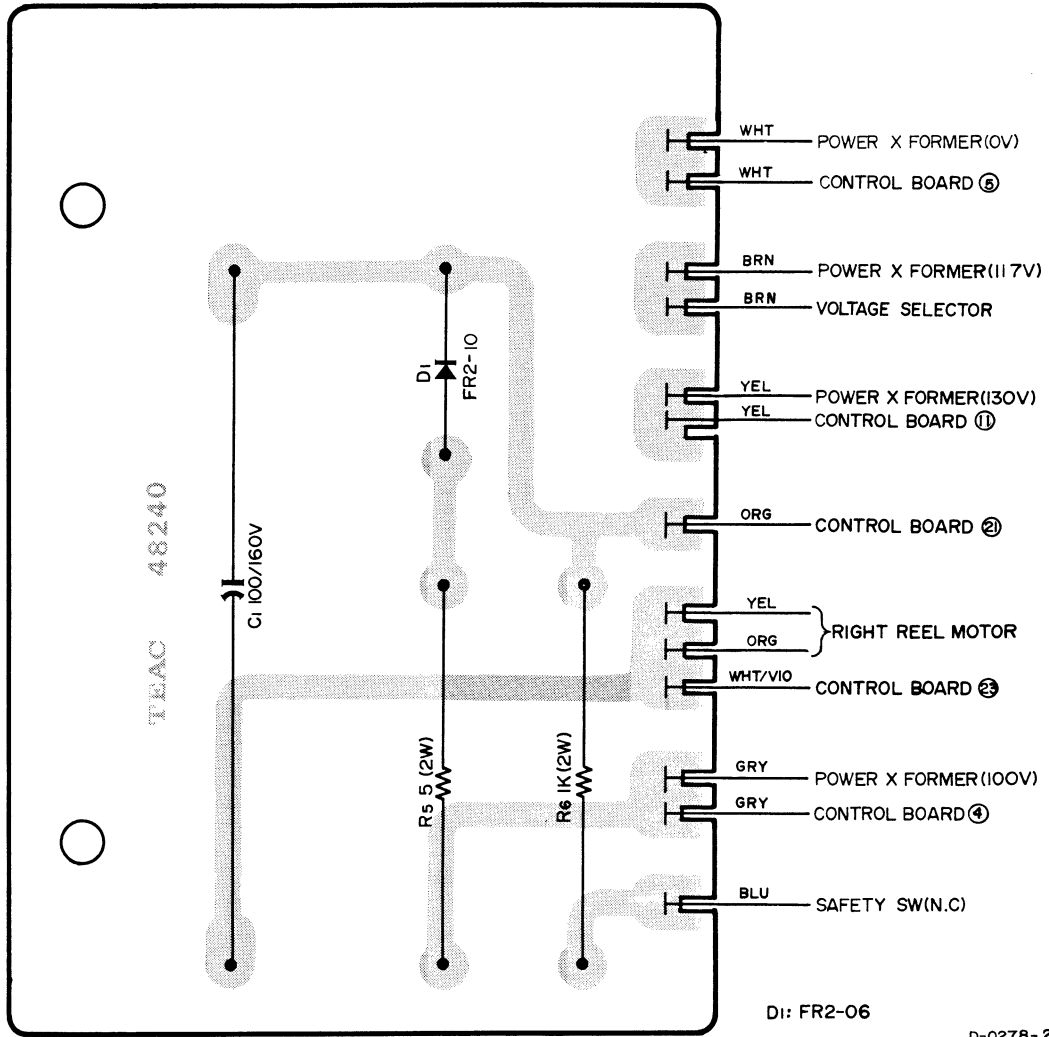

CIRCUIT REF.NO.	TEAC PARTS NO. DESCRIPTION	REVISION	
		1st	2nd
	50500500 PC Board Assy		
	50482400 PC Board		
D1	50422380 Diode FR2-10		
C1	50555250 Cap., Elec. 100 μ F 160V		
R5	50526030 Resistor, Wire Wound 5 Ω 2W		
R6	50578820 Resistor, Carbon 1k Ω 2W		

SCHEMATIC DIAGRAM
A-1250S

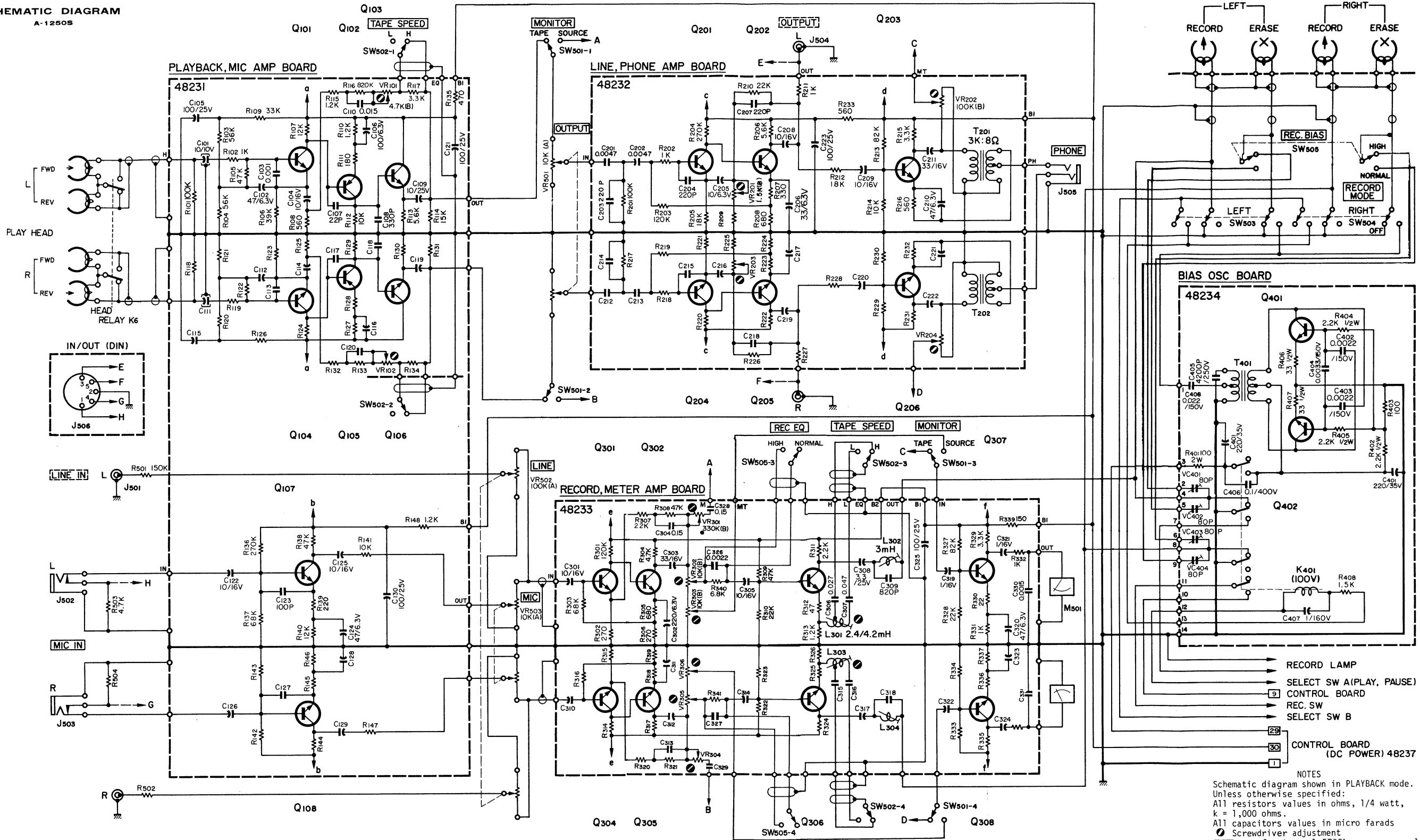

NOTES
Schematic diagram shown in PLAYBACK mode.
Unless otherwise specified:
All resistors values in ohms, 1/4 watt,
k = 1,000 ohms.
All capacitors values in micro farads
⊖ Screwdriver adjustment
□ : on front panel, ▭ : on rear panel.

6			
5			
4			
3			
2			
1	10-72		

STEREO TAPE DECK
PREAMPLIFIER
MODEL NO. **A-1250S**
SHEET NO. _____
TEAC CORPORATION
A.0101

CIRCUIT REF. NO.	DESCRIPTION	CIRCUIT REF. NO.	DESCRIPTION	CIRCUIT REF. NO.	DESCRIPTION
Q101/104	2SC732 (BL) or 2SC693 (F) or 2SC1000 (BL)	Q102/105	2SA494 (Y) or 2SA572 or 2SA666 (S)	Q201/204	2SC644 (T) or 2SC369 (BL) or 2SC693 (F)
Q103/106	2SC536 (E) or 2SC733 (Y) or 2SC828 (S)	Q107/108	2SC693 (F) or 2SC828 (S) or 2SC369 (BL)	Q203/205	2SC372 (Y) or 2SC536 (E) or 2SC828 (S)
		Q401/402	2SC971 (Y)		

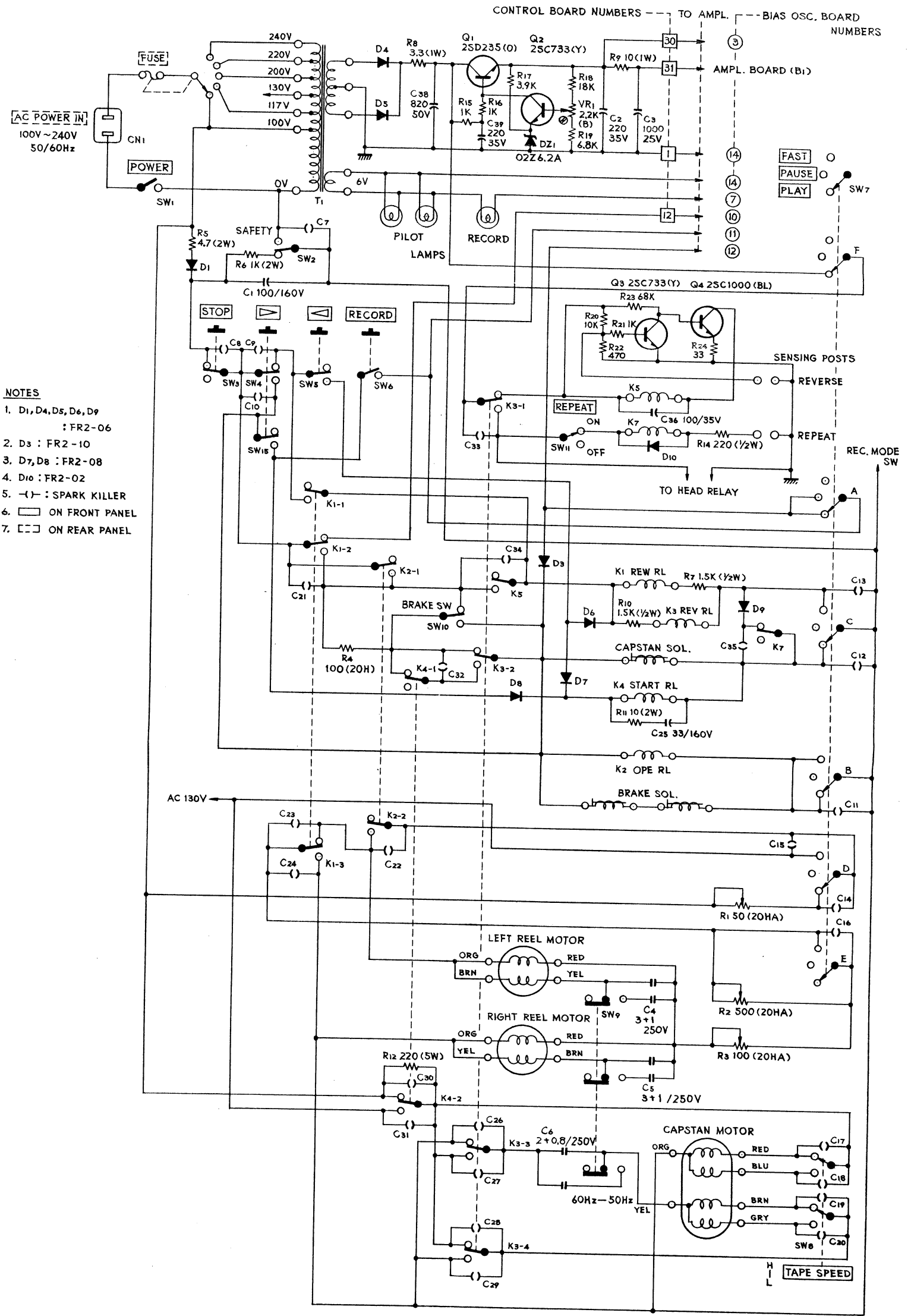

- NOTES**
1. D1, D4, D5, D6, D9 : FR2-06
 2. D3 : FR2-10
 3. D7, D8 : FR2-08
 4. D10 : FR2-02
 5. (-) : SPARK KILLER
 6. ON FRONT PANEL
 7. ON REAR PANEL

NOTES

ALL RELAYS SHOWN NOT ENERGIZED (STOP MODE)
 TAPE SPEED SWITCH SHOWN IN THE 7-1/2IPS POSITION
 FREQUENCY CONVERSION SWITCH SHOWN IN THE 60Hz POSITION

6			
5			
4			
3			
2			
1	10-72		
REVISION	DATE	CHANGE NO.	

STEREO TAPE DECK
TAPE TRANSPORT
 MODEL NO. **A-1250S** SHEET NO. **1**
TEAC CORPORATION

MANUAL CHANGES

Change notices, recommended modifications etc. will be issued for the models in this manual, when appropriate.

This sheet is in loose leaf form and should be filed behind this page for convenient reference.